

Sweepmaster P/D/B 1500 RH



(6464.10 /.15 /.20 /.30 /.40 /.50)

Schulung / Training

Fehlersuche / Trouble Shooting

Einstelldaten / Adjustments

Baukomponenten / Components

From may 2014 the machine names are changed. The „old“ name Jonas for sit-on sweepers is changed into Sweepmaster for all sweepers. The differentiation which machine is it exactly is done by the indication of kind of drive, sweeping width and operation concept (close to the old Hakomatics). In this training manual are the old names used. Here a comparison of the „old“ and „new“ names for this machine.

Jonas 1500 V **Sweepmaster P 1500 RH**

Jonas 1500 D **Sweepmaster D 1500 RH**

Jonas 1500 E **Sweepmaster B 1500 RH**

P means petrol-/gasoline-, D means diesel- and B stays for battery-model. The LP driven machines are still an option and didn't have an own name. The R means, it's a sit-on machine and the H stays for high dump.

0.0	Contents	2
1.0	Overview	6
1.1	Options	7
1.2	Operation	8
1.3	Technical data	10
2.0	Components	14
2.1.	Frame	14
2.2.	Sweeping system	15
2.2.1.	Rotary brush	15
2.2.2.	Side brush	16
2.2.3	Sweeping pattern	17
2.2.3.1	Basic settings	18
2.3.	Holding attachment / Dirt hopper	23
2.3.1.	Basic settings	24
2.4.	Steering / Wheel drive	26
2.5	Brakes	27
2.6	Engine	28
2.6.1	Diesel engine	28
2.6.2	Gasoline engine	31
2.6.2.1	Gasoline engine	31
2.6.2.2	LPG model	32

Service-Handbuch

Service Booklet

Page 4 of 124



3.0	Hydraulics	38
3.1.	V / D hydraulics	38
3.1.1.1	General information	38
3.1.1.2	Traction drive, short description	38
3.1.1.3	Work hydraulics, short description	38
3.1.2.1	Pumps (till 646410201733 or 646430202964)	39
3.1.2.2	Pumps (from 646410201744 or 646430202974)	42
3.1.3	Traction drive	47
3.1.3.1	Accelerator pedal	47
3.1.3.2	Hydrostatic drive	48
3.1.4	Work hydraulics	50
3.1.4.1	Valve manifold	50
3.2.	E hydraulics	56
3.2.1	General description	56
3.2.2	Valve manifold	57
3.2.3	Venting	60
4.0	Electric System	64
4.1.	V / D electric system	65
4.1.1	Components	65
4.1.2	Configuration	69
4.1.2.1	Accessing the configuration level	69
4.1.2.2	Configuration matrix	74
4.1.2.3	FPV table	78
4.1.3	Error messages	79

4.2.	E electric system	82
4.2.1.	General Information	83
4.2.2	Settings and programming the vehicle	84
4.2.2.1	Short description	85
4.2.2.2	Settings 1	88
4.2.2.3	Settings 2	94
4.2.2.4	Settings 3	98
4.2.2.5	Settings 4	103
4.2.2.6	Module settings	104
4.2.3	Error messages	105
4.2.4	Modules	110
4.2.4.1	A1	110
4.2.4.2	A2 + A3	111
4.2.5	Drive control	112
4.2.5.1	Error messages	114
5.0	Maintenance	125
5.1.	J1500 Diesel	125
5.2.	SWM D1500RH (Stage V)	126
5.3.	J1500 Gasoline	128
5.4.	J1500 LPG	129
5.5.	SWM P1500RH (Stage V)	130
5.6.	SWM P1500RH_LPG (Stage V)	132
5.7.	J1500 Electric	134

1.0 Overview

Internally, Hako does not consider the Jonas 1500 as a new development but rather as a modernization of the J1450. This is because many components have been taken over from predecessor models or adapted to fulfill new requirements. The components assumed include the frame, holding attachment, ABBA system and the hydraulics. New features include the design, engines and (in the case of the V and D models only) the electric system. Therefore, the Jonas 1500 implements an overhead throwing system and high dump hopper.

- 1) Side brushes
- 2) Traction drive
- 3) Rotary brush
- 4) Dirt hopper
- 5) Dust vacuum
- 6) Dust filter
- 7) Extractor fan



1.1 Options

Similar options will be available for the Jonas 1500 as for the J1450.

- Working lights
- Lights complying with StVZO (road traffic licensing regulations)
- Left-hand side brush
- 2nd side brush, for the right
- Cab safety roof
- Cab (with heater option)
- Flashing beacon
- LPG

1.2 Operation

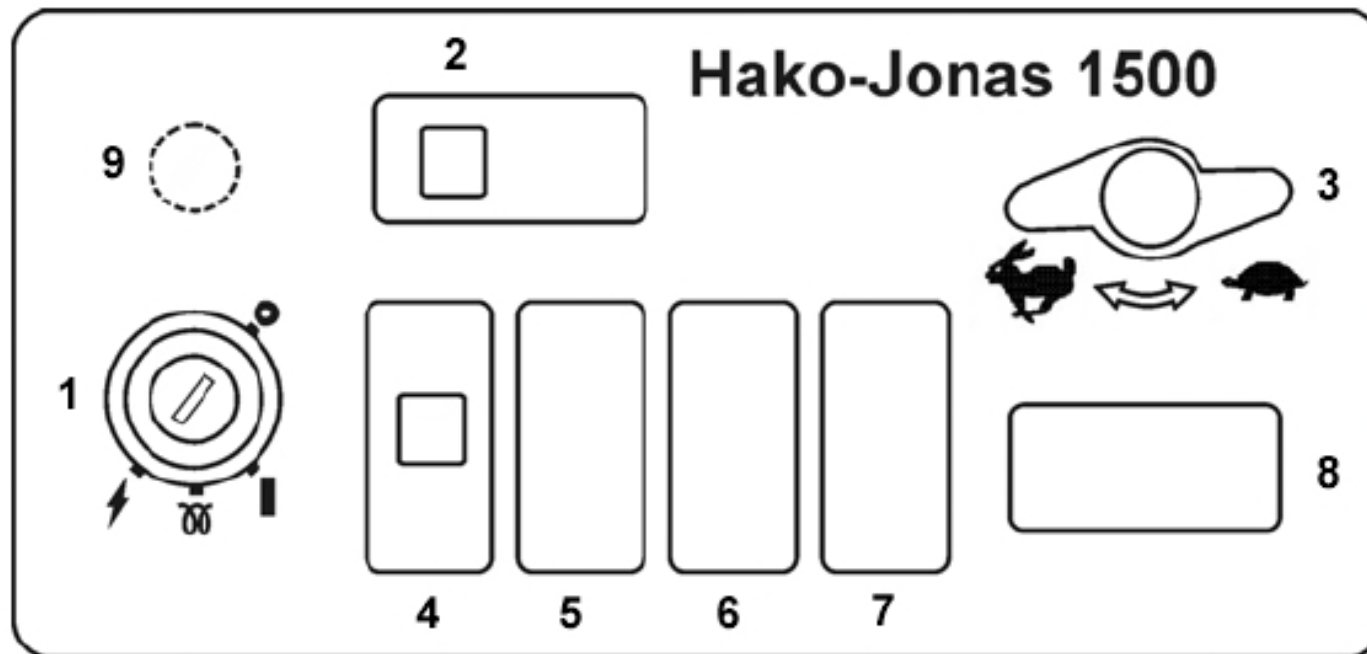

- | | |
|---|---|
| 1 | Ignition switch |
| 2 | Charge control lamp |
| 3 | Engine speed knob |
| 4 | Horn switch |
| 5 | Parking/Driving lights switch (option) |
| 6 | Hazard lights switch (option) |
| 7 | Flashing beacon (option) |
| 8 | Driving direction switch with control lamp (option) |
| 9 | Choke (Hako-Jonas 1500 V only) |

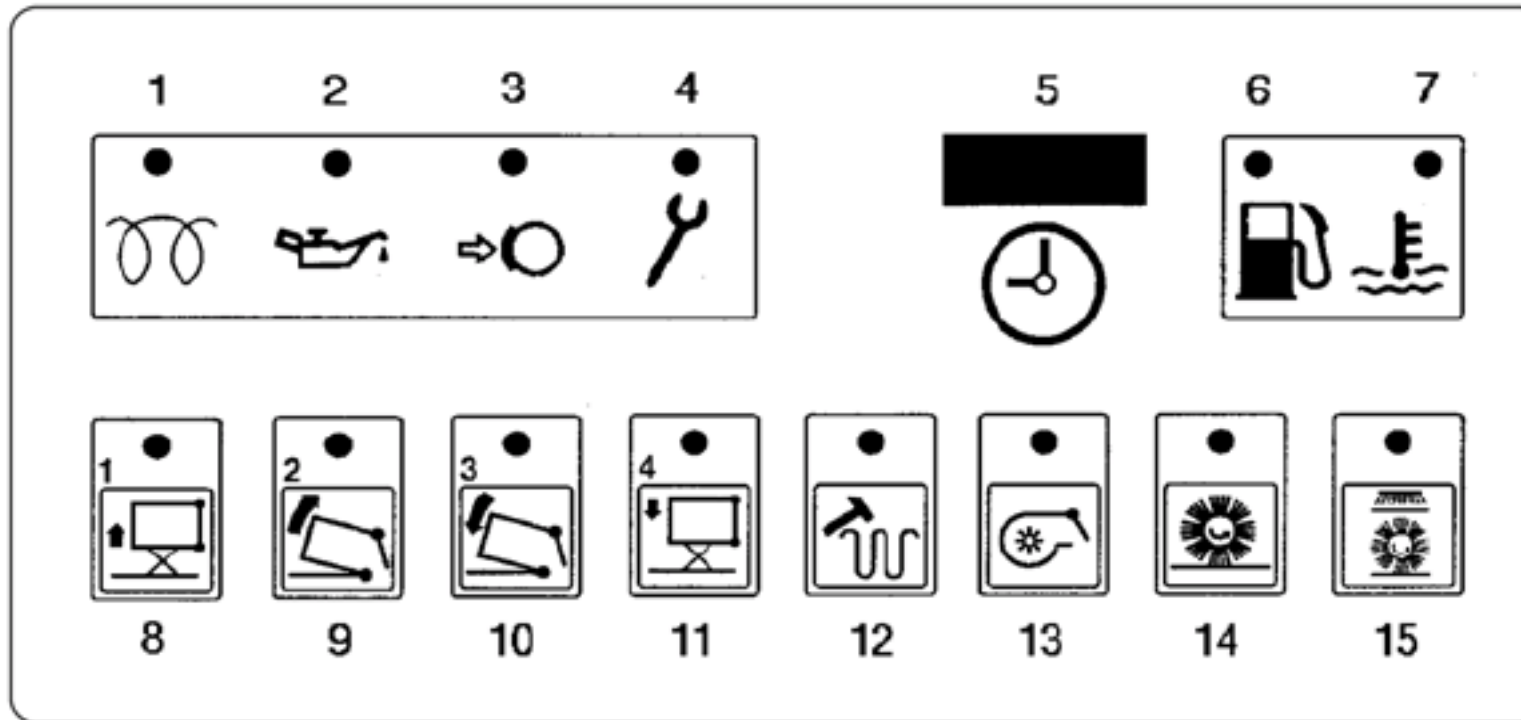

- | | |
|----|--|
| 1 | Preheating control lamp |
| 2 | Engine oil pressure control lamp |
| 3 | Parking brake control lamp |
| 4 | Service indicator control lamp |
| 5 | Operating hours counter / Diagnostics code |
| 6 | Residual fuel control lamp |
| 7 | Coolant temperature control lamp |
| 8 | Raise dirt hopper button |
| 9 | Pivot dirt hopper away for emptying button |
| 10 | Pivot dirt hopper in emptying button |
| 11 | Lower dirt hopper button |
| 12 | Filter shaking system |
| 13 | Suction fan button |
| 14 | Rotary brush button |
| 15 | Rotary and side brush button |

The accelerator pedal for forward/reverse drive is on the right-hand side of the foot area. The brake pedal, with holding brake lock, and rotary brush pressure pedal are on the left-hand side of the foot area. There is also a pedal for the coarse particle flap.

1.3 Technical Data

Function	J1500 V	J1500 LPG	J1500 D	J1500 E
Dimensions and weights				
Length (mm)	2256	2256	2256	2256
Width (mm)	1316	1316	1316	1316
Height (mm)	1751	1751	1751	1751
Working width with 1 side brush (mm)	1270	1270	1270	1270
Working width with 2 side brushes (mm)	1620	1620	1620	1620
Dumping height of hopper (mm)	1520	1520	1520	1520
Turning circle (mm)	3600	3600	3600	3600
Dead weight (kg)	1107	1108	1110	1465
Permissible total weight (kg)	1900	1900	1900	1900
Permissible axle load, front (kg)	700	700	700	700
Permissible axle load, rear (kg)	1200	1200	1200	1200
Engine				
Manufacturer / Type	Kubota DF752	DF752 + IMPCO	Kubota D902	
Engine size (kW)	15	14	14	
Capacity (ccm)	740	740	898	
Idling speed (rpm)	1500 +/-50	1500 +/-50	1500 +/-50	
Max. full-load speed (rpm)	2700 +/-50	2700 +/-50	2700 +/-50	
Engine oil	15 W -40 / CF-4	15 W -40 / CF-4	15 W -40 / CF-4	
Fill quantity (l)	3.25	3.25	2.5	
Coolant	Coolelf Auto Supra -37°	Coolelf Auto Supra -37°	Coolelf Auto Supra -37°	
Fill quantity (l)	3.5 / 5 (heater)	3.5 / 5 (heater)	3.5 / 5 (heater)	
Generator (A)	40	40	40	
Battery (V / Ah)	12 / 54	12 / 54	12 / 54	
Fuel consumption (l/h; Kg/h)	3	1.9	2.2	

Funktion	SWM P1500 RH	SWM P1500 RH LPG	SWM P1500 RH DualFuel	SWM D1500 RH
Motor				
Manufacturer / Type	Kubota WG752	Kubota WG752	Kubota WG752	Kubota D902 E4B
Engine size (kW)	15	14	14 / 15	14 / 15
Capacity (ccm)	740	740	740	898
Idling speed (rpm)	1500 +/-50	1500 +/-50	1500 +/-50	1500 +/-50
Max. full-load speed (rpm)	2700 +/-50	2700 +/-50	2700 +/-50	2700 +/-50
Engine oil	10W -30 / CF-4	10W -30 / CF-4	10W -30 / CF-4	10W -30 / CF-4
Fill quantity (l)	3,25	3,25	3,25	2,5
Coolant	Coolelf Auto Supra -37°	Coolelf Auto Supra -37°	Coolelf Auto Supra -37°	Coolelf Auto Supra -37°
Fill quantity (l)	3,5 / 5 (heater)	3,5 / 5 (heater)	3,5 / 5 (heater)	3,5 / 5 (heater)
Generator (A)	40	40	40	40
Battery (V / Ah)	12 / 54	12 / 54	12 / 54	12 / 54
Fuel consumption (l/h; Kg/h)	3		3	2,2

Function	J1500 V	J1500 LPG	J1500 D	J1500 E
Hydraulics				
Hydraulic pump (ccm/rev)	15	15	15	
Speed (rpm)	2800 +/- 50	2800 +/- 50	2800 +/- 50	
Feed pressure (bar)	8	8	8	
PCV running pressure (bar)	275	275	275	
Speed, hydraulic motor, forwards (rpm)	140 +/- 5	140 +/- 5	140 +/- 5	
Speed, forwards (kph)	0 - 10	0 - 10	0 - 10	0 - 8
Speed, hydraulic motor, reverse (rpm)	88 +/- 5	88 +/- 5	88 +/- 5	
Speed, reverse (kph)	0 - 6	0 - 6	0 - 6	0 - 4
Working pump, rotary brush (ccm/rev)	6	6	6	
Speed (rpm)	2800 +/- 50	2800 +/- 50	2800 +/- 50	
PCV rotary brush (bar)	160	160	160	
Working pump, side brush and holding attachments (ccm/rev)	3.5	3.5	3.5	
Speed (rpm)	2800 +/- 50	2800 +/- 50	2800 +/- 50	
PCV side brush and holding attachment (bar)	200	200	200	
Speed, rotary brush (rpm)	500 + 30	500 + 30	500 + 30	
Speed, side brush (rpm)	95 + 5	95 + 5	95 + 5	
Hydraulic oil	HVLP 46	HVLP 46	HVLP 46	
Fill quantity (l)	28	28	28	
Sweeping				
Sweeping pattern (mm)	90	90	90	75
Clearance, front skirt (mm)	0	0	0	0
Clearance, side sealing strips (mm)	2	2	2	4
Clearance, rear sealing strips (mm)	5 + 1	5 + 1	5 + 1	7 + 1
Usable dirt hopper volume (l)	240	240	240	240
Permissible weight in dirt hopper (kg)	450	450	450	450

Air volume, suction (m ³ /h)		1250	1250	1250	
Vacuum, suction (Pa)		2800	2800	2800	
Function		J1500 V	J1500 LPG	J1500 D	J1500 E
Filter					
Filter, dust classification		L in accordance with EN 60335-2-69	L in accordance with EN 60335-2-69	L in accordance with EN 60335-2-69	L in accordance with EN 60335-2-69
Noise level					
Sound pressure level (dB(A))		80	80	84	?
Power consumption					
Traction drive, levels (A)					
Traction drive, 16% gradient (A)					
Rotary brush drive (A)					
Side brush drive (A)					
Suction (A)					
Shake (A)					

2.0 Components

2.1 Frame

The steel frame of the Jonas 1500 is constructionally similar to the frame of the J1450. All other components are installed on and in it.

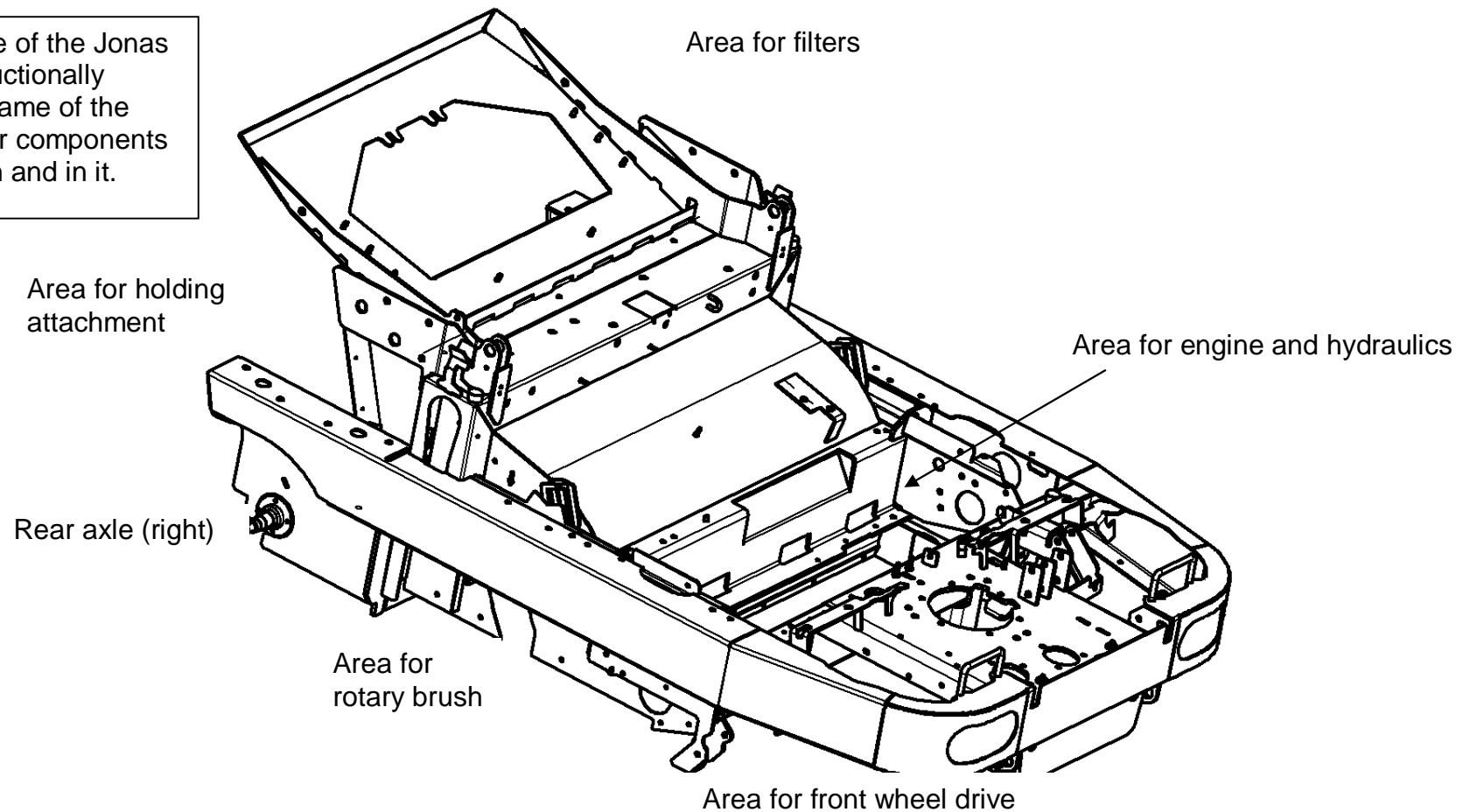

2.2 Sweeping system

2.2.1 Rotary brush

The main sweeping section has changed in comparison to the J1450 in as far as the Bowden cables for sweeping pattern adjustment have been moved "to the top".

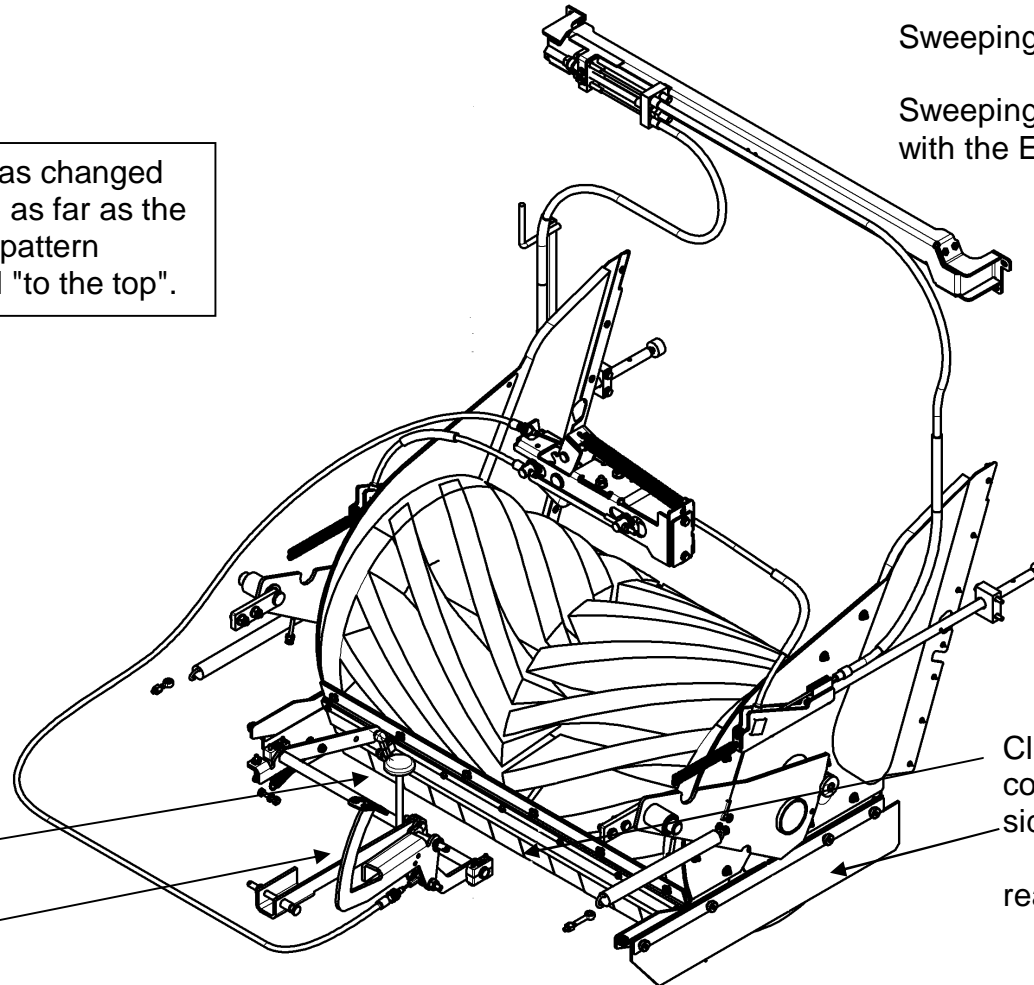

Sweeping pattern adjustment / ABBA system

Sweeping pattern with V/D models, 90 mm
with the E model, 75 mm

Coarse particle flap

Rotary brush pressure

Clearance dimensions for the
coarse particle flap 0 mm
side sealing strips 2 mm (V/D)
4 mm (E)
rear sealing strip 5 mm (V/D)
7 mm (E)

2.2.2 Side brush

The side brush is the same as that installed in the J1450

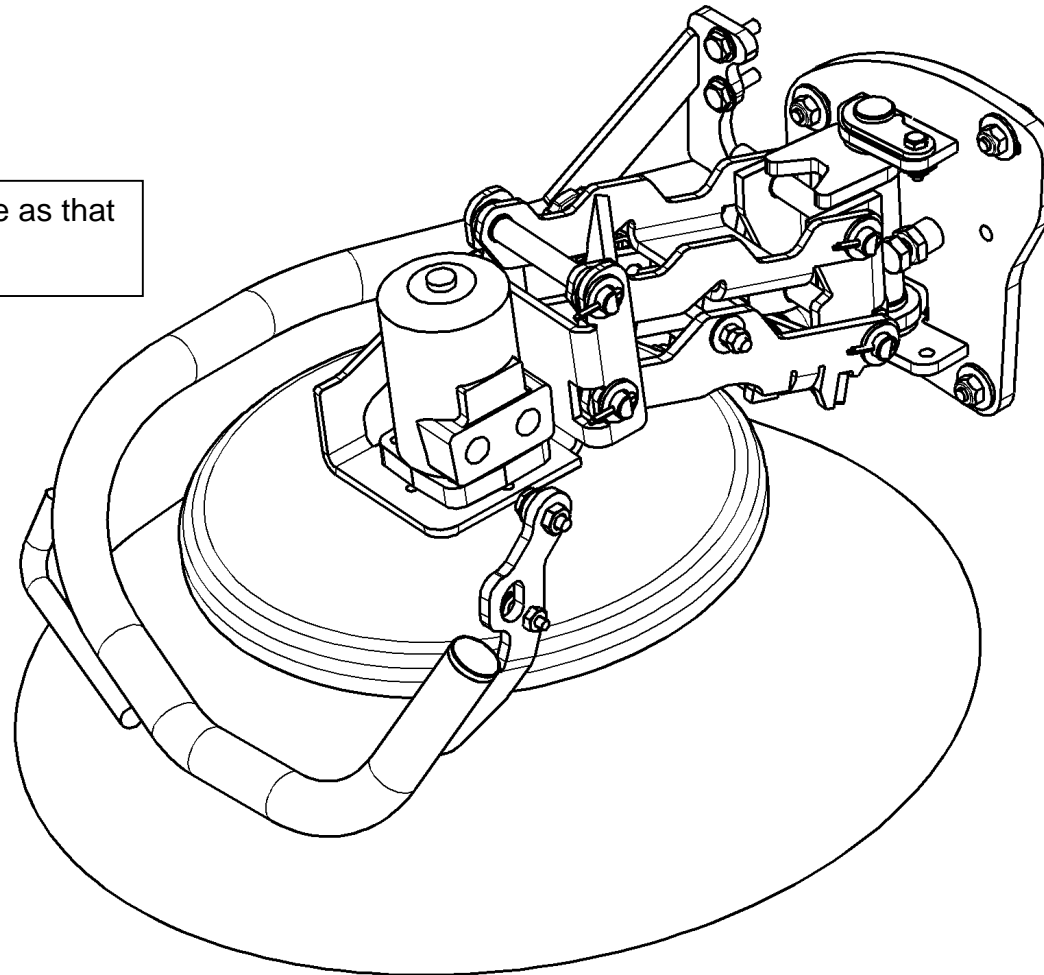

It can be adjusted (following wear) using the handwheel (not illustrated, installed on the other side).
A nut is also provided there with which to alter the angle of inclination. The side brush should make contact with the ground in the area from 11 – 3 o'clock.

2.2.3 Setting the sweeping pattern / ABBA system

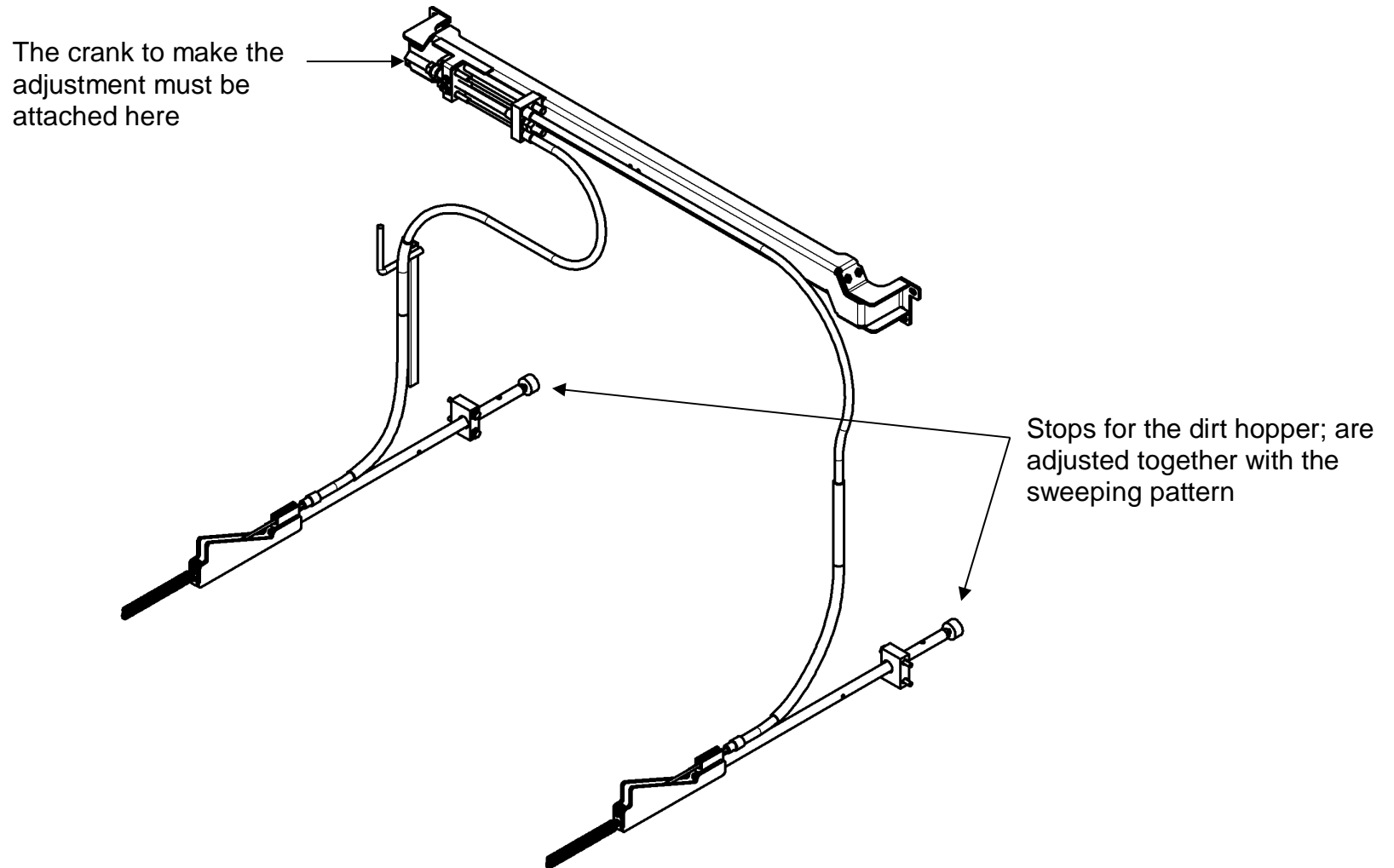

2.2.3.1 Basic setting



Stop for the carriage on the bush (cover removed)

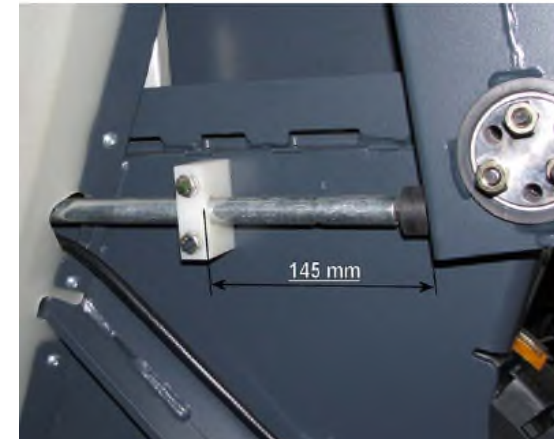

Distance between stop-buffer for PA guide
145 mm
(with brand new Bowden cables)
with Bowden cables already installed
140 mm
(applies on both sides)

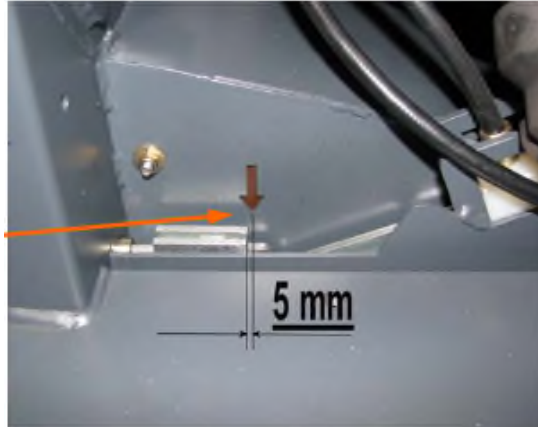

With brand new Bowden cables: Distance from arrow tip to carriage surface:

5 mm

With Bowden cables installed for longer:

Congruent



Bearing for Bowden cable end nipple



Front edge of pointer plate flush to 1st notch of the mark

Right-hand Bowden
cable **short**

Left-hand Bowden cable
long



(1)

(2)

Eyelet bolts for Bowden cables on the
brush arms (both sides)

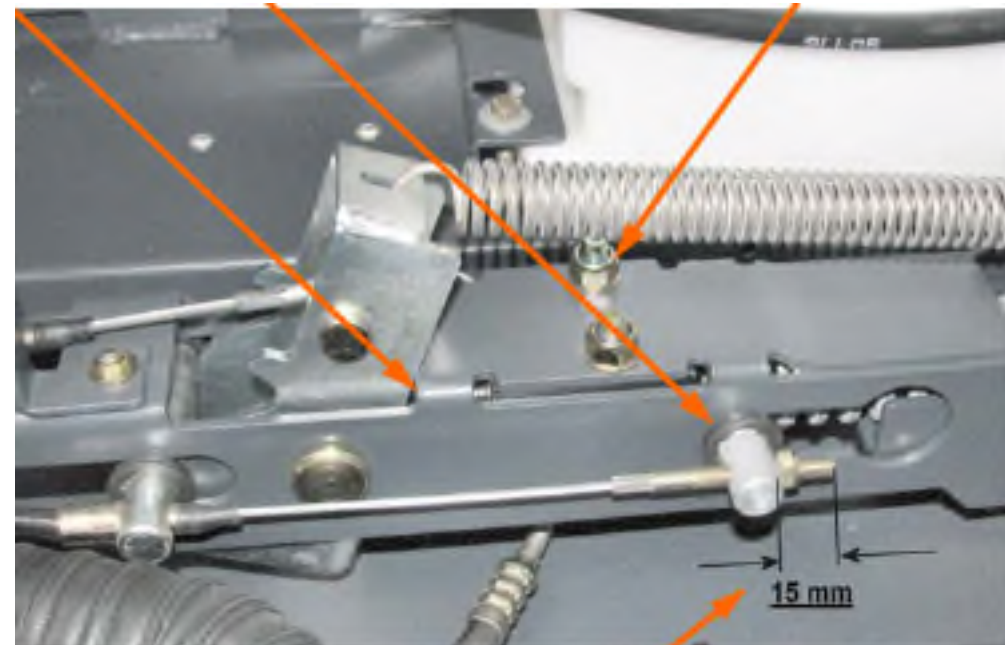

Condition: The rotary brush cylinders must be lowered!!!

Angle bracket (1) and bolt (2) make contact

Preset to **15 mm** on both sides; fine adjustment to set a parallel
sweeping pattern

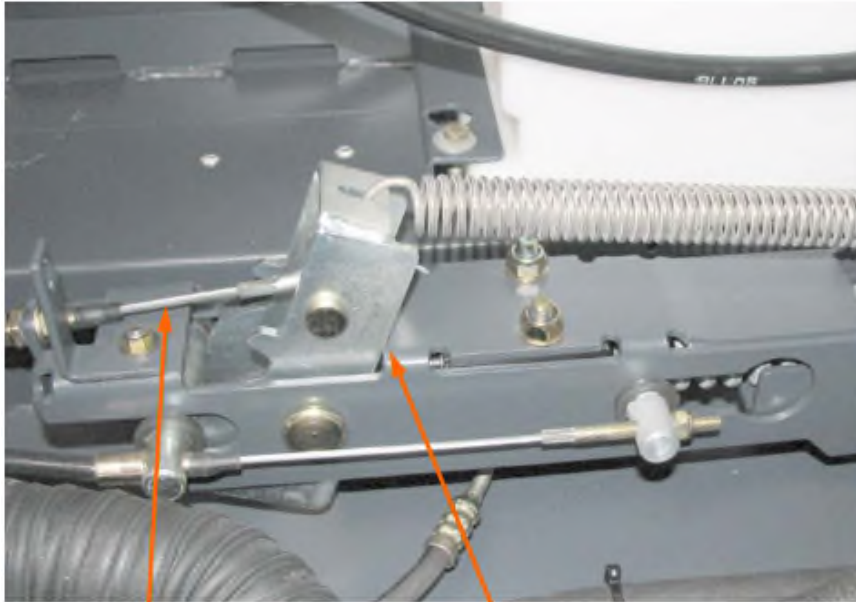

Tension the brake cable so that the angle retains contact

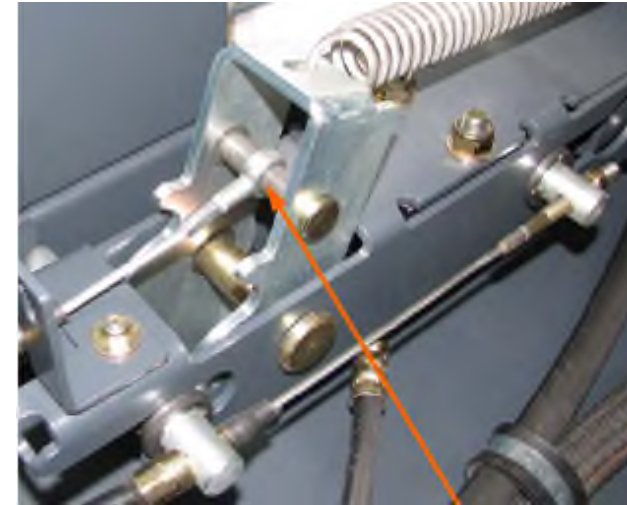

Locating bolt of the Bowden cable

Final check:

- When raised, the brush arm must not make contact with the chassis
- When in a "brush worn" state (D = 400 mm), the distance from the stop buffer to the PA guide must be **30 mm** (existing Bowden cable)
- The Bowden cables stretch after longer operation!!! (**Approx. 5 mm**)

Pedal not actuated!!!



2.3 Holding attachment / Dirt hopper

The holding attachment and dirt hopper are only marginally different from those used in the J1450

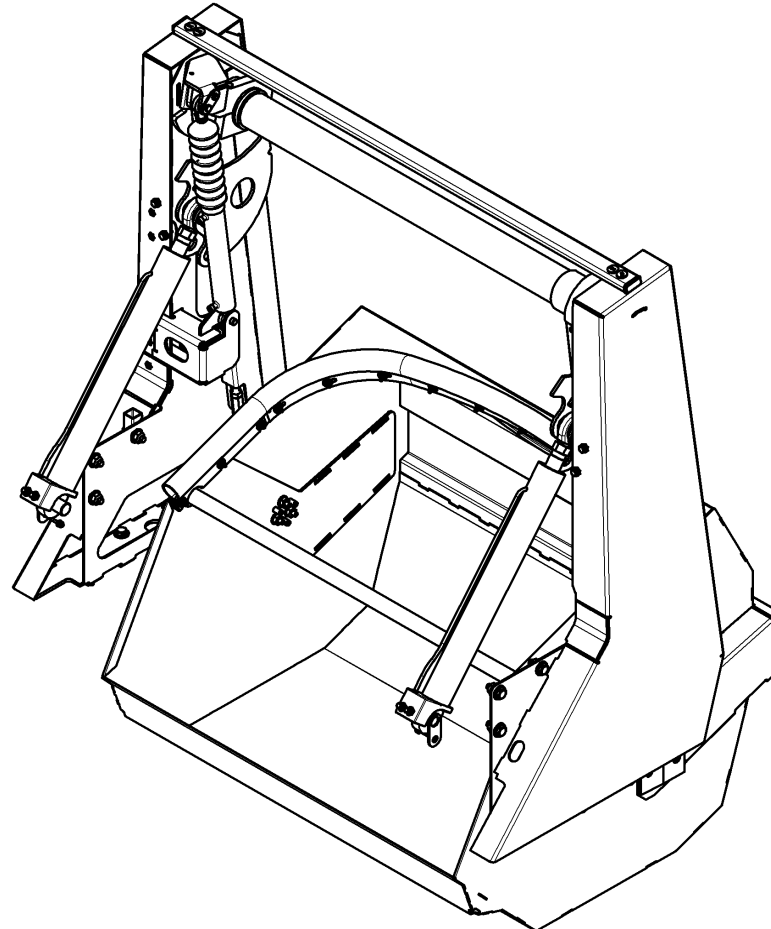

2.3.1 Basic setting

1. Raise, support and disassemble the dirt hopper
 2. Disconnect all the hydraulic cylinders from the hopper rocker arm.
 3. Support the hopper rocker arm, from below, at the pipe on the left-hand side in an appropriate way and disassemble the left tower.
 4. Pull the rocker arm out of the bearing of the right-hand tower and set it down. (Right-hand tower remains assembled.)
 5. Drive the three locking pins, located in the journal, in the pipe. Remove the socket head screws.
 6. Use a punch (max. 24 mm Ø; approx. 1000 mm long) to drive the journal out through the pipe from the left-hand side.
 7. Remove the tipping cylinder holder by releasing the bearing bracket.
 8. Pull the sprocket out of the housing after removing the cover.
 9. Disassemble the lower sprocket by removing the journal.
 10. Thread the chain in the housing and insert the 6th link pin in the tooth base marked by a punch mark in the lower sprocket.
 11. Mount the chain by driving in the journal.
 12. Insert the 7th link pin in the top sprocket in the marked tooth base.
 13. Assemble the cover and tipping cylinder holder with the bearing bracket.
 14. Join the chain and tension in the lock using a tightening torque of 25 Nm.
 15. Turn the top sprocket, tipping cylinder holder and intermediate ring until all the holes are exactly in line with the threaded holes.
 16. Drive the journal in ensuring the holes are in line and fix in place with the socket head screws.
 17. Drive the locking pins, previously removed from the pipe, in the free holes in the journal.
- Assemble the hopper arm tower and dirt hopper.

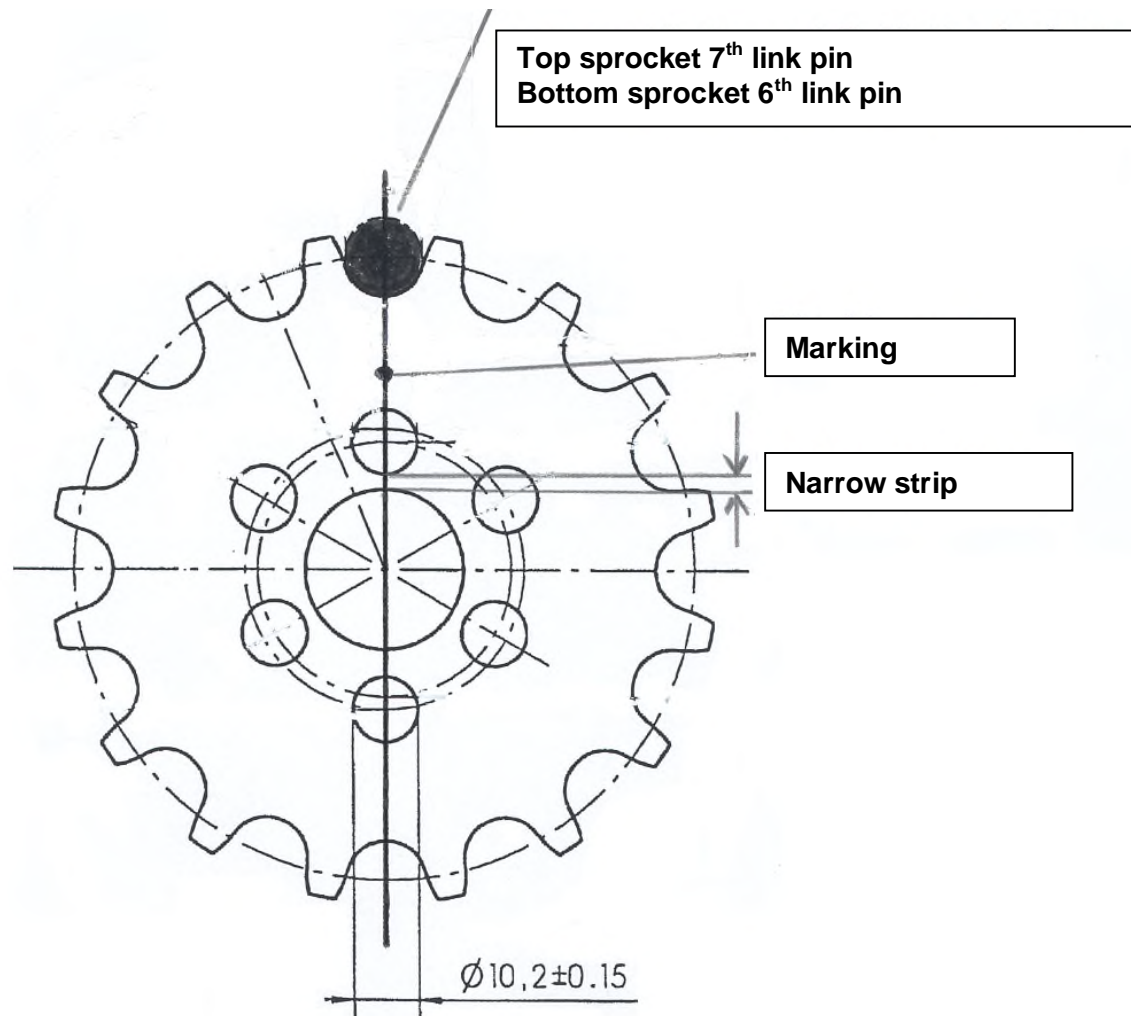

2.4 Steering / Wheel drive

Attention!
Roller chain must not have any play.

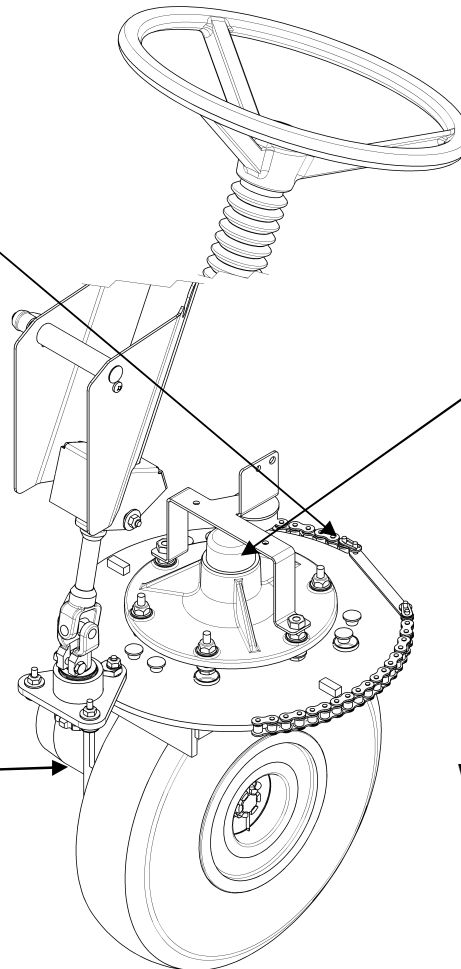

- Assembling the tapered roller bearing:
- 1) Tighten the axle nut at 65 Nm, thereby moving the wheel mount.
 - 2) Loosen the axle nut sufficiently to produce an axial play of 0.03 – 0 mm. (It should be just possible to move the washer with a screwdriver.)

Tightening torque for the
4 hydraulic motor bolts
90 Nm

Wheel nut tightening torque
400 +100 Nm
Assemble the cone free

2.5 Brakes

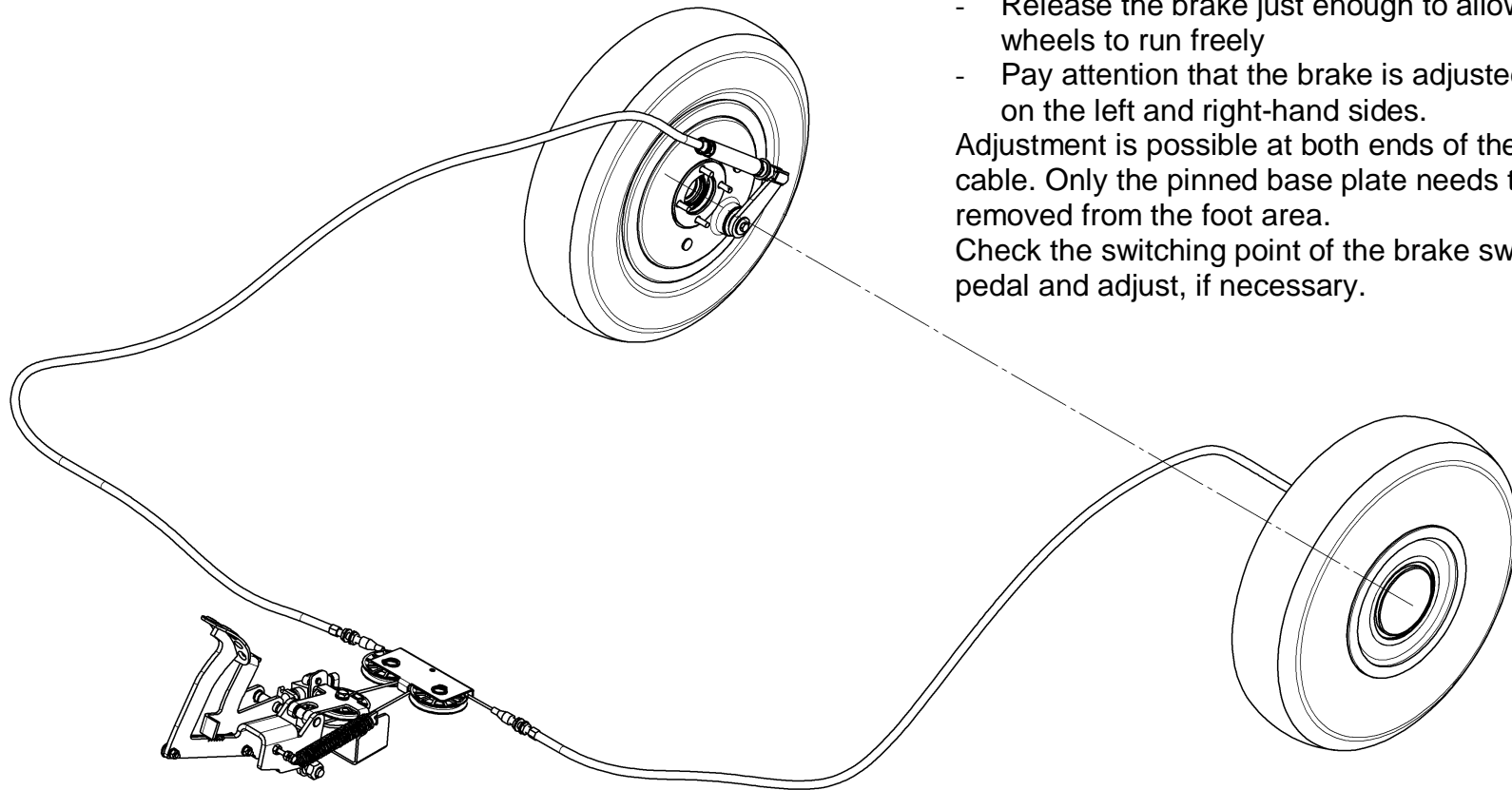

Adjusting the brakes:

- Block the wheels by applying the brake
- Release the brake just enough to allow the wheels to run freely
- Pay attention that the brake is adjusted equally on the left and right-hand sides.

Adjustment is possible at both ends of the Bowden cable. Only the pinned base plate needs to be removed from the foot area.

Check the switching point of the brake switch on the pedal and adjust, if necessary.

2.6 Engine

2.6.1 Diesel engine

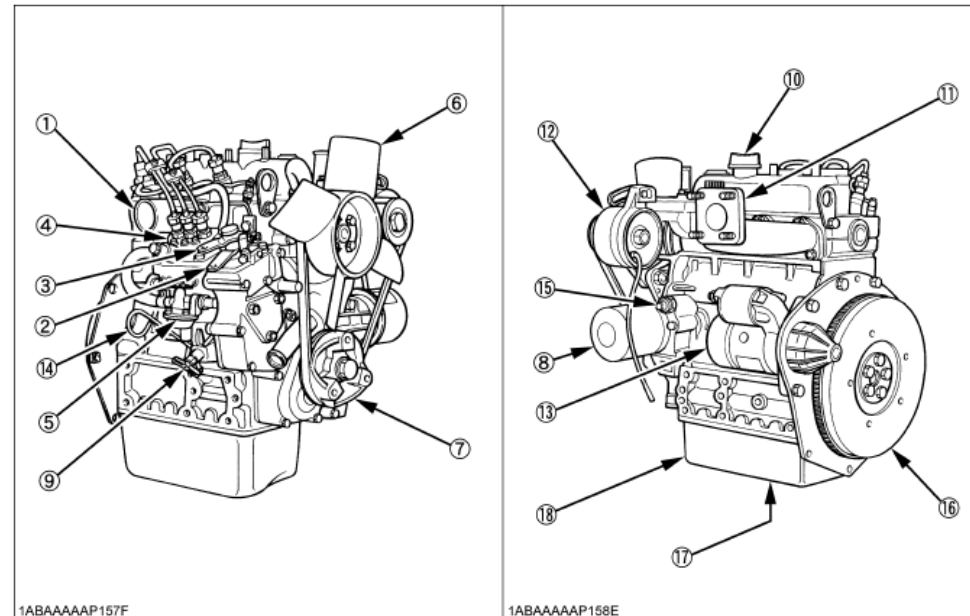

- | | | | |
|---|------------------------|----|----------------------|
| 1 | Inlet manifold | 10 | Oil filling neck cap |
| 2 | Speed regulation lever | 11 | Exhaust manifold |
| 3 | Stop engine lever | 12 | Alternator |
| 4 | Injection pump | 13 | Starter |
| 5 | Fuel pump | 14 | Dipstick |
| 6 | Ventilator | 15 | Oil pressure switch |
| 7 | Pulley | 16 | Flywheel |
| 8 | Oil filter insert | 17 | Oil drain bolt |
| 9 | Water drain cock | 18 | Oil sump |

Service-Handbuch Service Booklet

Page 28 of 124



Manufacturer	:	Kubota
Type	:	D 902-E3B-EU-X7
Cylinders / Strokes	:	3 / 4-stroke
Power output at 2700 rpm	:	14.0 kW
Bore x stroke	:	72 x 73.6 mm
Capacity	:	898 ccm
Idling speed	:	1500 rpm
Max. full-load speed	:	2750 +/-50 rpm
Combustion chamber	:	Swirl chamber (E-TVCS)
Speed control	:	Centrifugal force controlled regulator
Fuel injection timing	:	20° before TDC
Ignition sequence	:	1 - 2 - 3
Injection pressure	:	137 bar
Compression	:	24 : 1
Cold start aid	:	Glow plugs
Fuel	:	Diesel fuel in accordance with EN 590
Engine oil	:	15 W-40 / Classification CF
Oil quantity	:	2.5 l
Fuel consumption	:	2.2 l/h.

New Engine from SN 646430006971 (Stage V)

Manufacturer	:	Kubota
Type	:	D 902-E4B-EU-X7
Cylinders / Strokes	:	3 / 4-stroke
Power output at 2700 rpm	:	14.0 kW
Bore x stroke	:	72 x 73.6 mm
Capacity	:	898 ccm
Idling speed	:	1500 rpm
Max. full-load speed	:	2750 +/-50 rpm
Combustion chamber	:	Swirl chamber (E-TVCS)
Speed control	:	Centrifugal force controlled regulator
Fuel injection timing	:	20° before TDC
Ignition sequence	:	1 - 2 - 3
Injection pressure	:	137 bar
Compression	:	24 : 1
Cold start aid	:	Glow plugs
Fuel	:	Diesel fuel in accordance with EN 590
Engine oil	:	15 W-40 / Classification CF
Oil quantity	:	2.5 l
Fuel consumption	:	2.2l/h

2.6.2 Gasoline engine

2.6.2.1 Gasoline engine

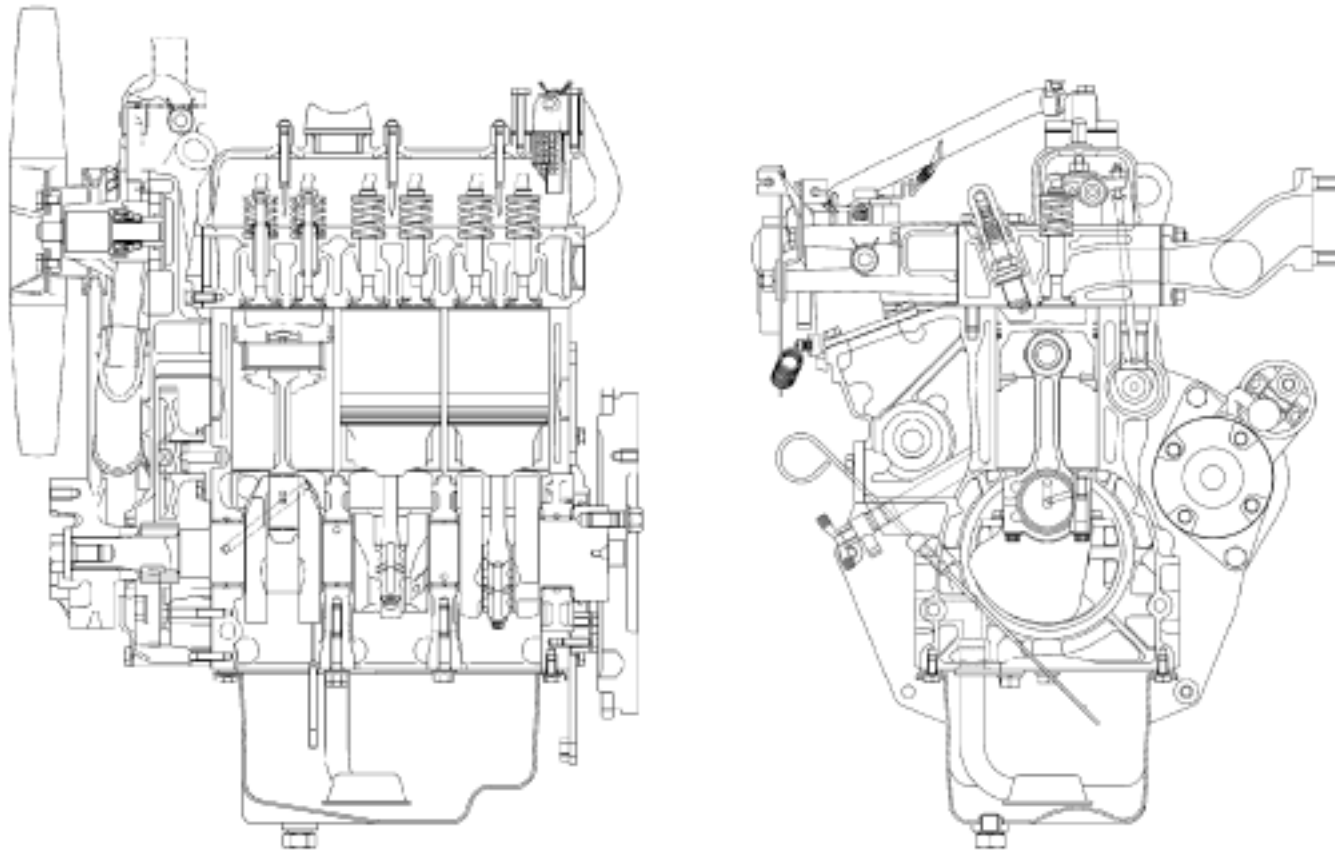

Service-Handbuch Service Booklet

Page 31 of 124



Manufacturer	:	Kubota
Type	:	DF 752-E2-BBH
Cylinders / Strokes	:	3 / 4-stroke
Power output at 2700 rpm	:	15.0 kW
Power output, LPG	:	14.3 kW ?
Bore x stroke	:	68 x 68 mm
Capacity	:	740 ccm
Idling speed	:	1500 rpm
Max. full-load speed	:	2700 +/-50 rpm
Speed control	:	Mechanical centrifugal force speed regulator
Ignition system	:	Transistor ignition with distributor
Ignition timing	:	18° before TDC
Ignition sequence	:	1 - 2 - 3
Compression	:	9.2 : 1
Fuel	:	Unleaded automotive gasoline
LPG	:	Standard LPG (H-D-5 / GPA standard)
Engine oil	:	15 W-40 / Classification >SF
Oil quantity	:	3.25 l
Fuel consumption	:	3.0 l/h.

Service-Handbuch Service Booklet



2.6.2.2 LPG model

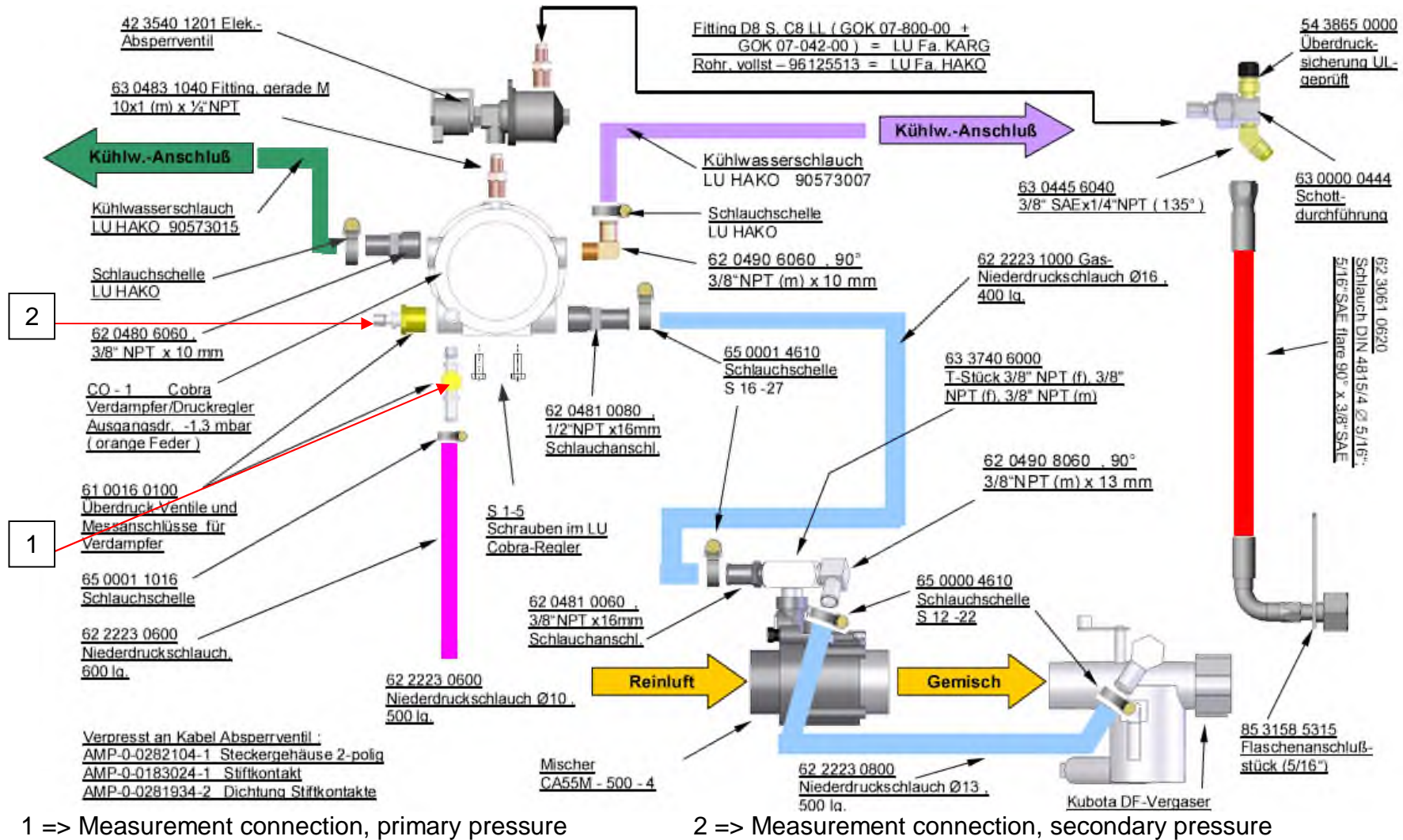

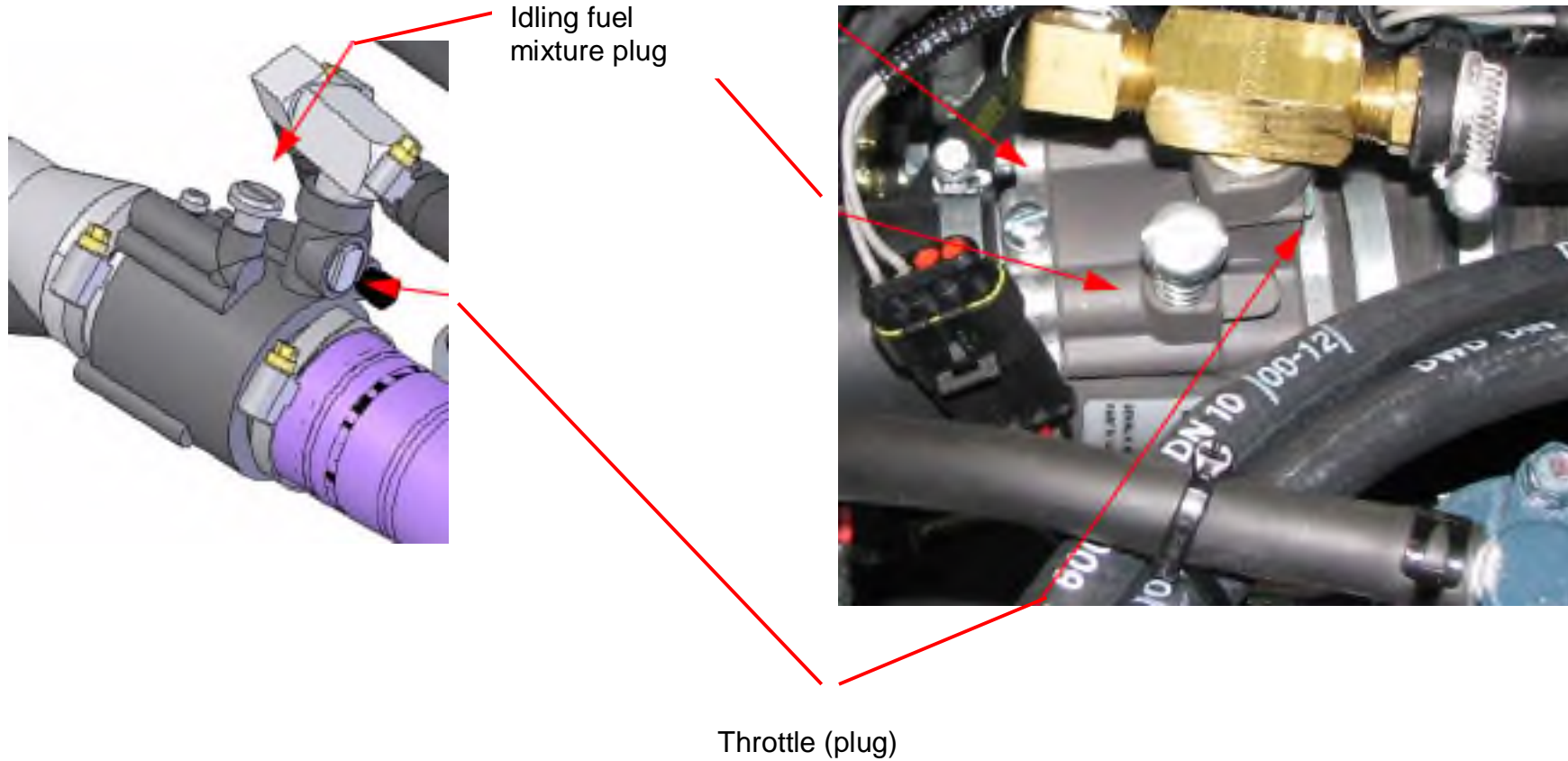

Procedure:

1) Six-monthly check in respect of CO content

- Turn the throttle (plug) on the air fuel mixer to a position 1 mm towards "R" (from its center position).
- Unscrew the spring-locked, idling fuel mixture plug completely and then screw it back in 10 mm.
- Start the engine and run to at operating temperature.
- Set the idling speed to 1500 rpm.
- Set the CO value to <0.1% on the idling fuel mixture plug (strive for a value between 0.08% and 0.1%).
- Set the engine to a max. speed of 2700 rpm. Switch on the sweeping function (main brush, side brush and vacuum)
- Use the throttle (plug) to regulate the CO₂ value to approx. 12%.
- Check the CO value at idling speed again (< 0.1%) and readjust, if necessary.
- After the adjustment, seal the idling fuel mixture plug and choke with sealing paint.

2) Annual leak test

- Inspect the entire system for signs of damage.
- Disconnect the bottle connecting adapter from the LPG bottle.
- Open the LPG check valve (12 V at X75 PIN1)
- Execute the pressure hold test from the adapter to the vaporizer.

New engine (Stage V) in the variations 6464.15 (P1500R), 6464.20 (P1500RH LPG), 6464.50 (P1500RH Dual Fuel)

Manufacturer	:	Kubota
Type	:	WG752-GL-E3BBH-HAK-1
Cylinders / Strokes	:	3 / 4-stroke
Power output at 2700 rpm	:	15.0 kW
Power output, LPG	:	14.3 kW ?
Bore x stroke	:	68 x 68 mm
Capacity	:	740 ccm
Idling speed	:	1500 rpm
Max. full-load speed	:	2700 +/-50 rpm
Speed control	:	Mechanical centrifugal force speed regulator
Ignition system	:	Transistor ignition with distributor
Ignition timing	:	18° before TDC
Ignition sequence	:	1 - 2 - 3
Compression	:	9.2 : 1
Fuel	:	Unleaded automotive gasoline
LPG	:	Standard LPG (H-D-5 / GPA standard)
Engine oil	:	15 W-40 / Classification >SF
Oil quantity	:	3.25 l
Fuel consumption	:	3.0 l/h.

3.0 Hydraulics

3.1 V/D hydraulics

3.1.1.1 General information

The hydraulic units are practically maintenance-free.
Maintenance work on the hydraulic system only involves changing the oil and filter within the scope of keeping the system clean.
Regular monitoring and periodic servicing helps prevent premature failures.

3.1.1.2 Traction drive V/D, short description

Vehicles equipped with combustion engines are also provided with a hydrostatic traction drive which operates within a closed system. The driving speed can be mechanically regulated on the pump and is infinitely variable for forward and reverse using the accelerator. The accelerator automatically returns to its neutral setting when released resulting in a dynamic deceleration and self-locking against the vehicle rolling away inadvertently.

If it is necessary to move the vehicle when the engine has been stopped, the bypass valve on the pump must be opened. The pump pressure is controlled by two PCVs (for forward and reverse). They are set to 275 bar (for forward and reverse).

3.1.1.3 Work hydraulics, short description

All the functions are hydraulically controlled in the case of the V and D models. The hydraulic power is supplied via two gear pumps and a valve manifold. The functions are controlled electrically via solenoid valves.

3.1.2.1 Pumps (till 646410201733 or 646430202964)

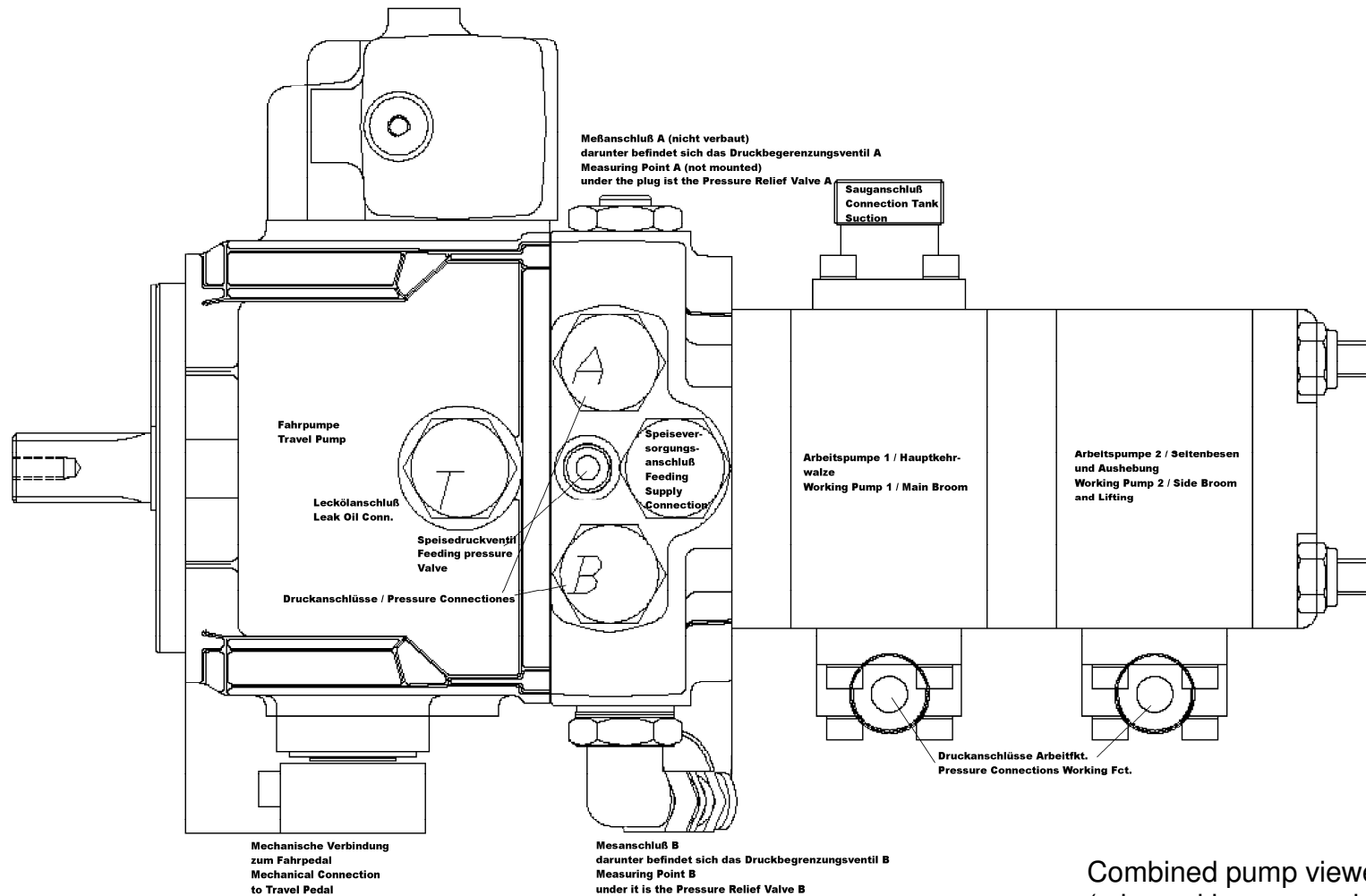

Combined pump viewed from below
(mirrored image, engine is to the right)

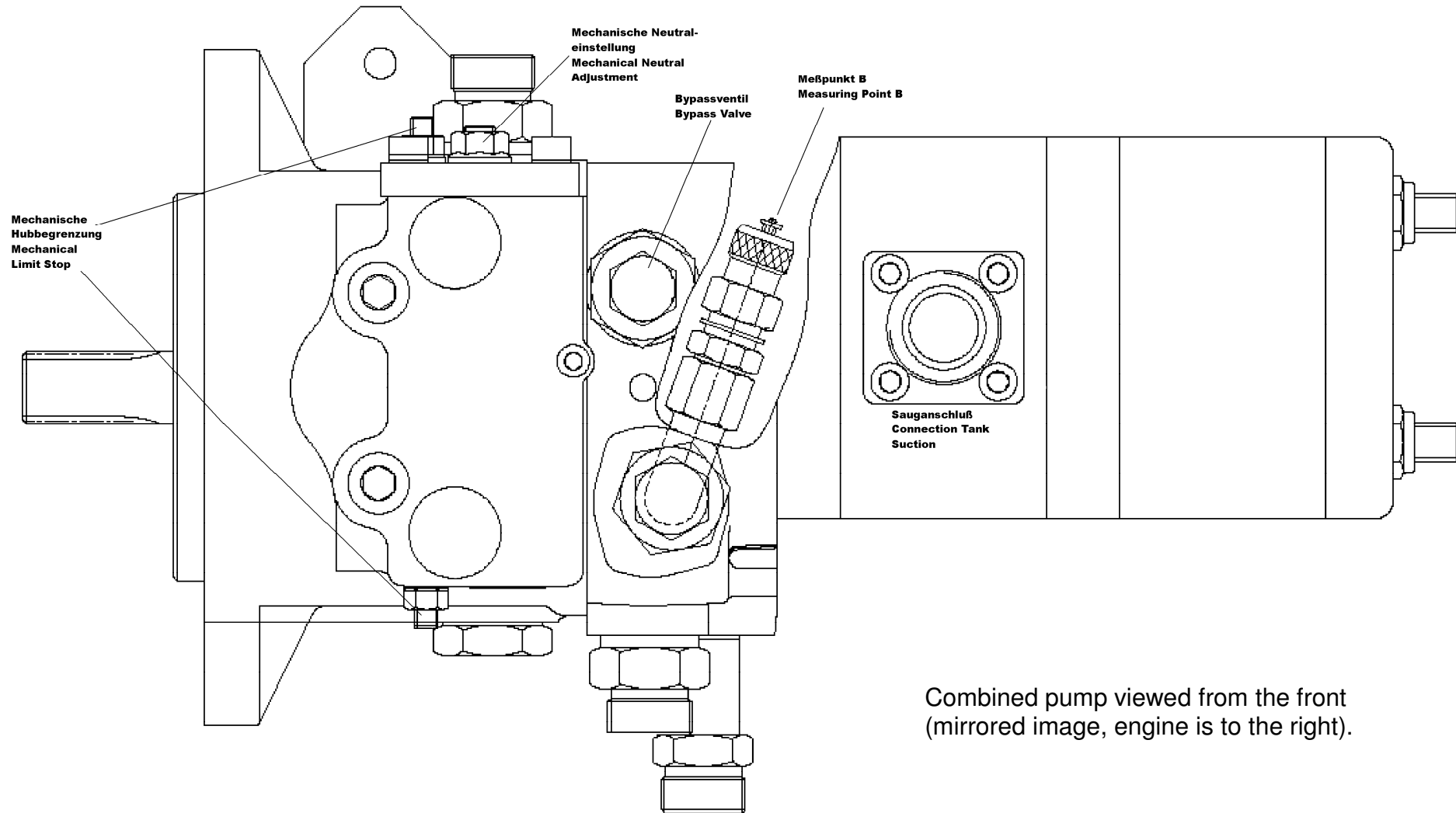

Combined pump viewed from the left looking to the front
(rotated 90°)

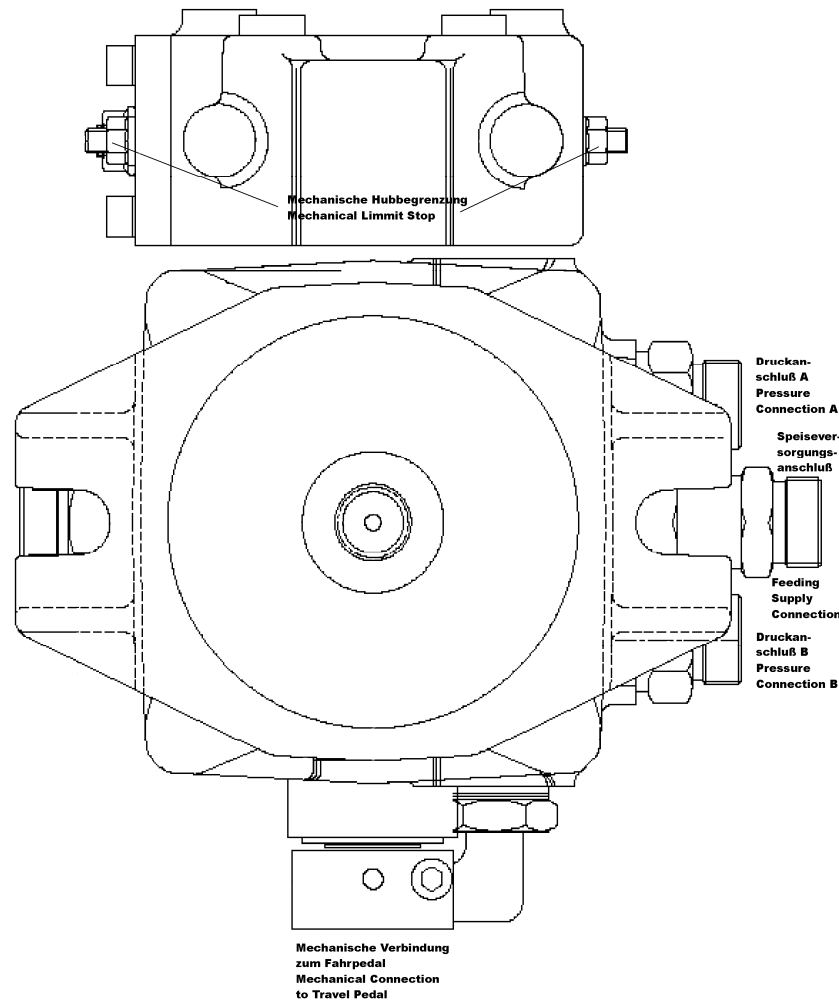

Technical Data

Manufacturer:

Comer
V1 15 S2 H 00 80 27 R 08 00 G 06 +
03 Bh PP 08 ES

Hydraulic pump:

Type	Axial piston pump
Feed capacity	15 cm ³ /rev
Load speed	2700 rpm
⇒	38.5 l/min

Working pump 1:

Type	Gear pump
Feed capacity	6 cm ³ /rev
Load speed	2700 rpm
⇒	18.7 l/min

Working pump 2:

Type	Gear pump
Feed capacity	3.5 cm ³ /rev
Load speed	2700 rpm
⇒	9.2 l/min

3.1.2.1 Pumps (from 646410201744 or 646430202974)

right

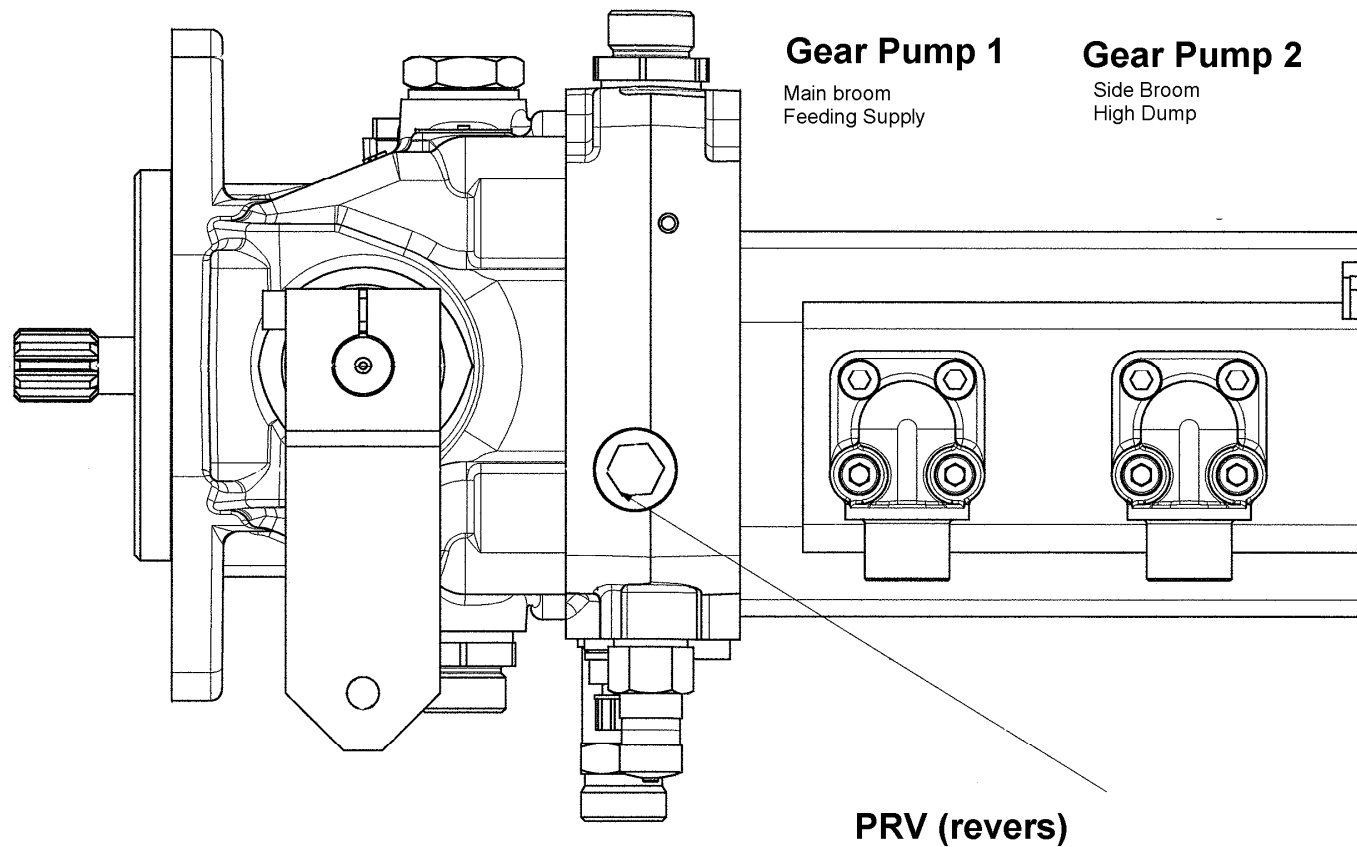

left

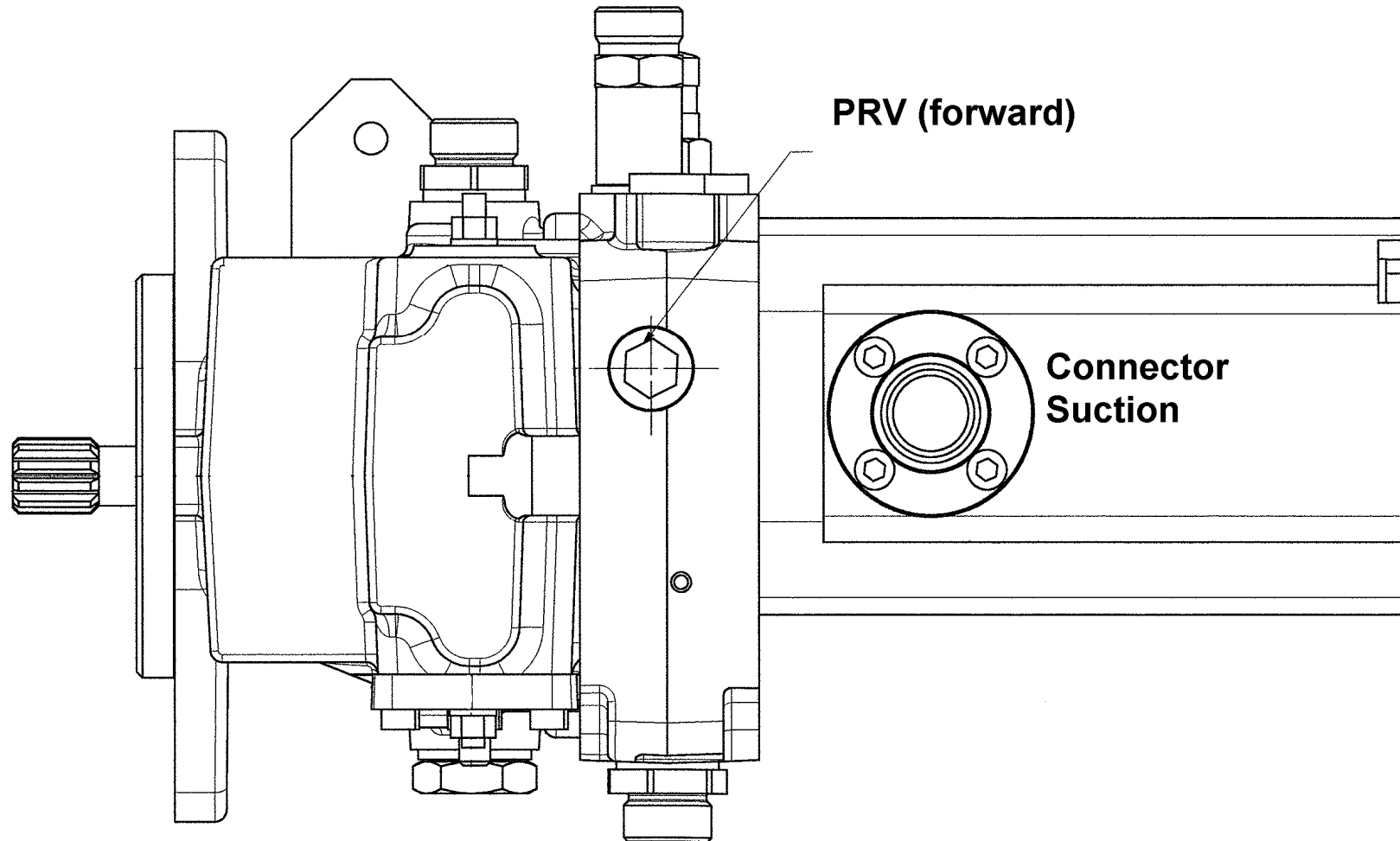

from above

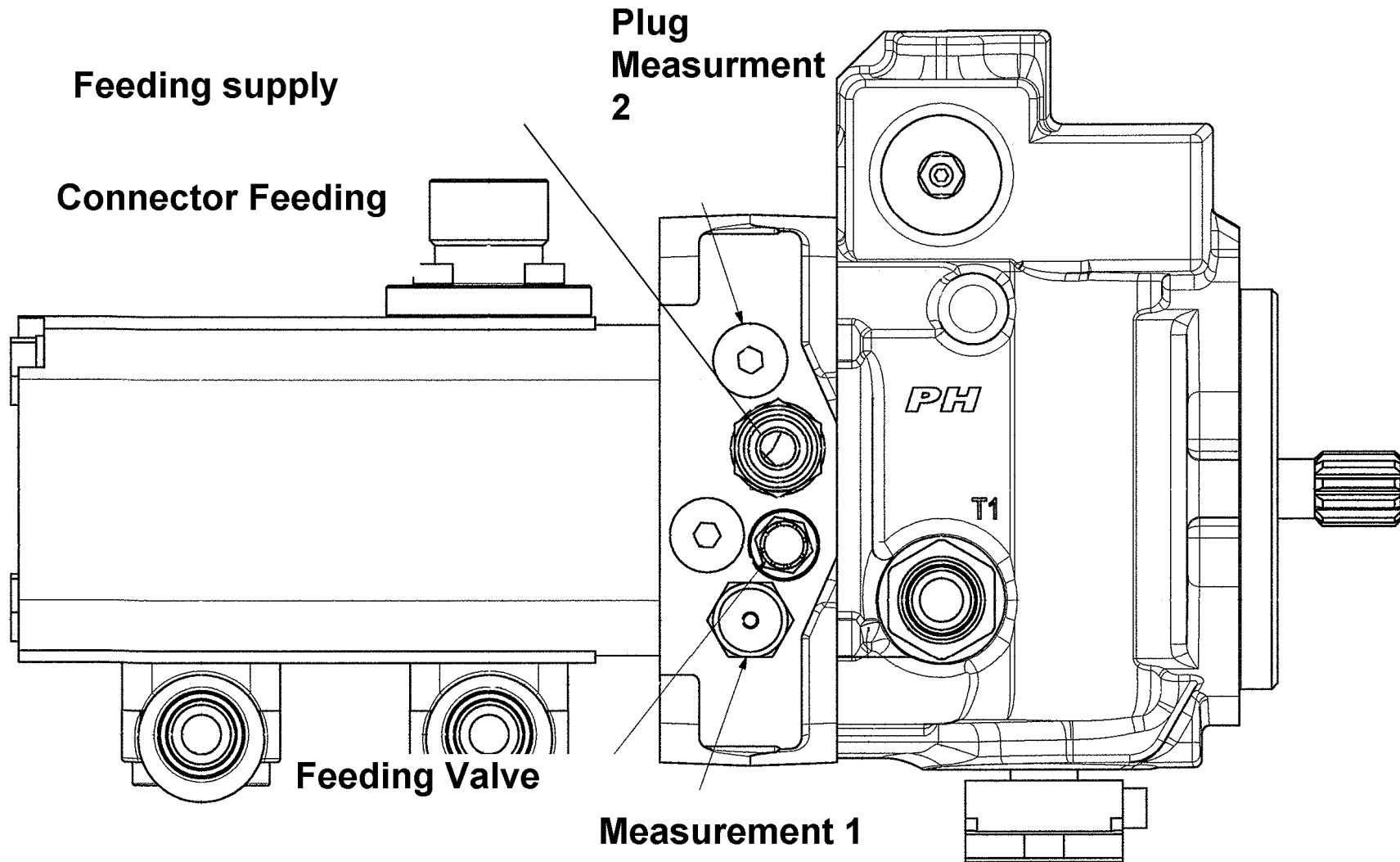

from underknees

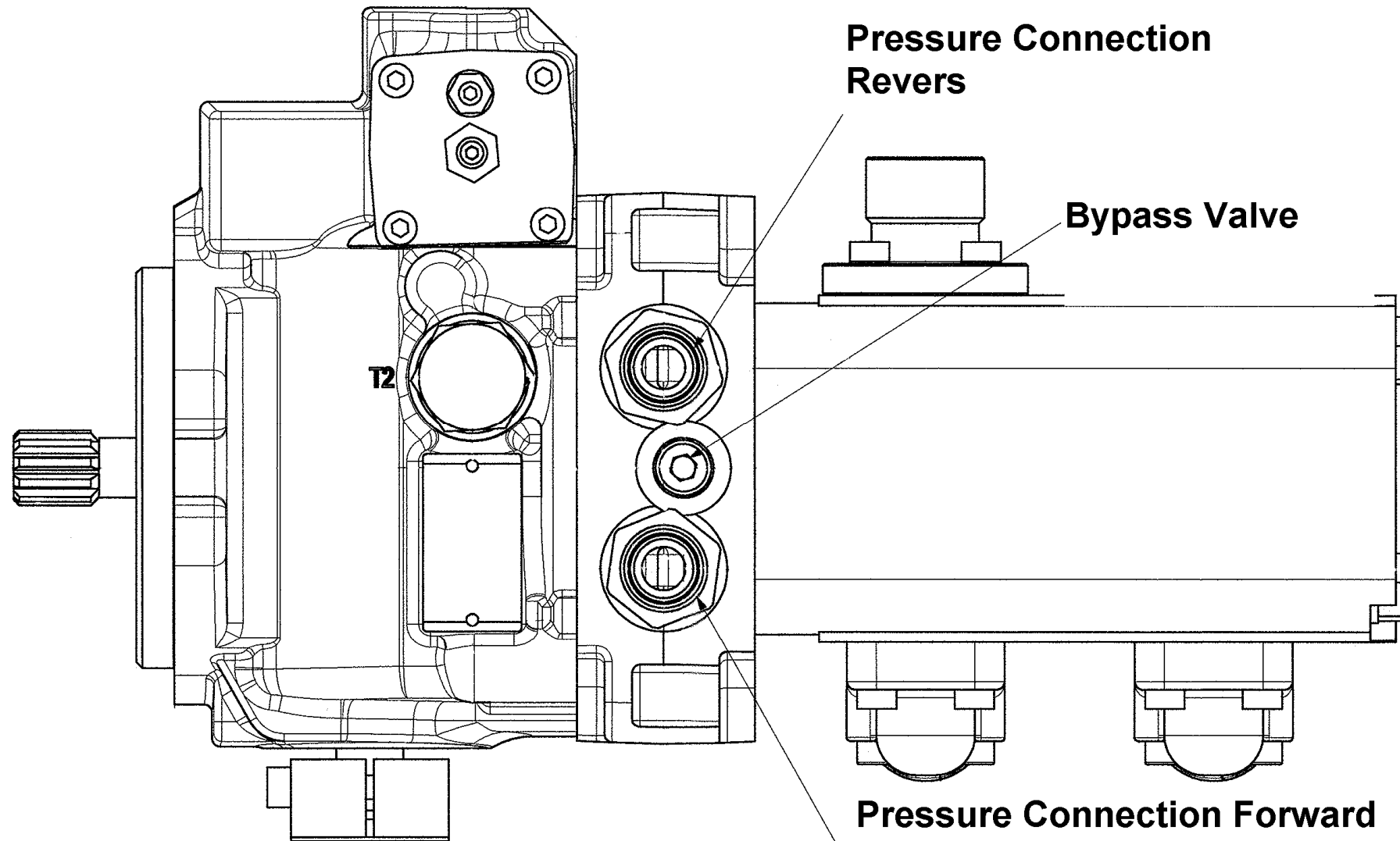

front

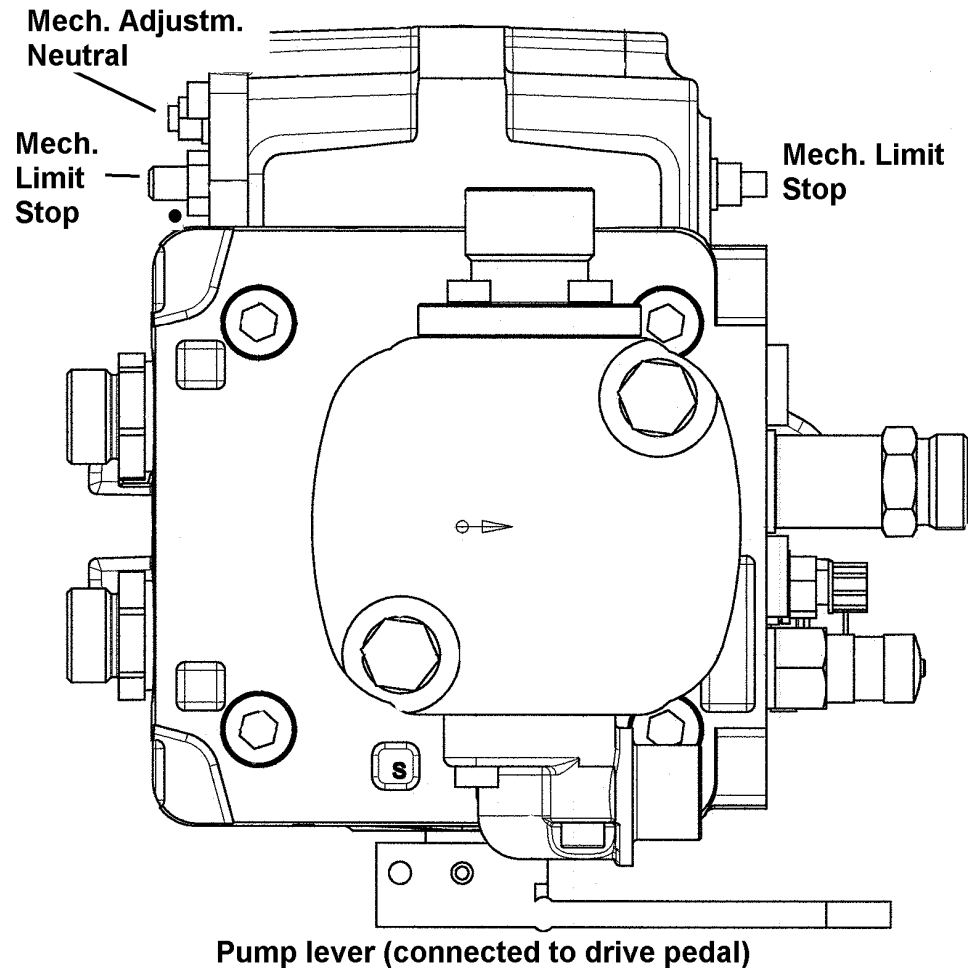

Technical Data

Manufacturer:

Poclain Hydraulics Industriale
PM10B15S2NBL27R0800G06+03ES

Travel pump:

Typ	Axial Piston Pump
Displacement	15 cm ³ /U
Load Speed	2700 1/min
⇒	38,5 l/min

Work Pump 1:

Typ	Gear Pump
Displacement	6 cm ³ /U
Load Speed	2700 1/min
⇒	18,7 l/min

Work Pump 2:

Typ	Gear Pump
Displacement	3,5 cm ³ /U
Load Speed	2700 1/min
⇒	9,4 l/min

3.1.3 Traction drive

3.1.3.1 Accelerator pedal

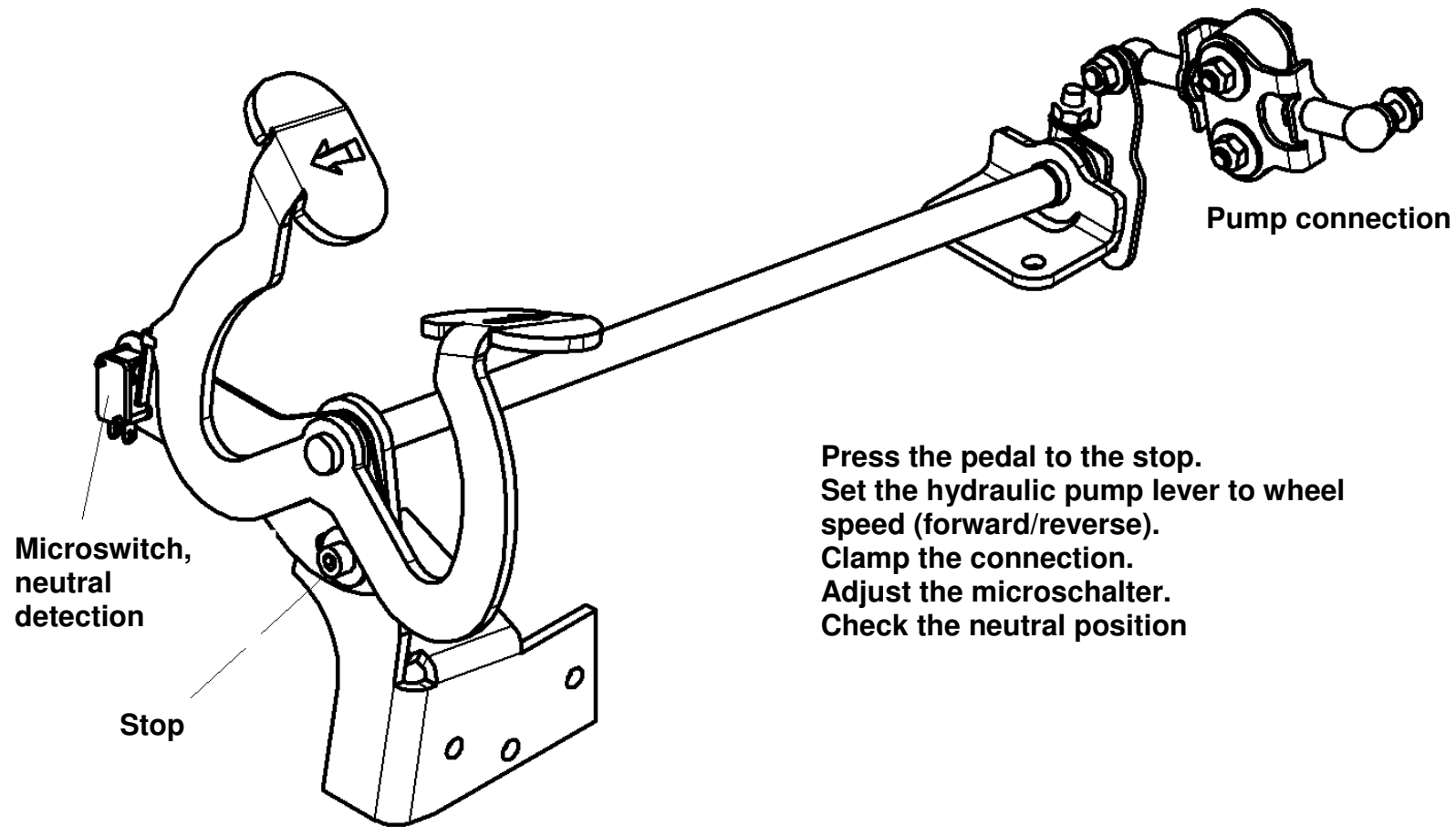

Press the pedal to the stop.
Set the hydraulic pump lever to wheel speed (forward/reverse).
Clamp the connection.
Adjust the microscharter.
Check the neutral position

3.1.3.2 Hydrostatic drive

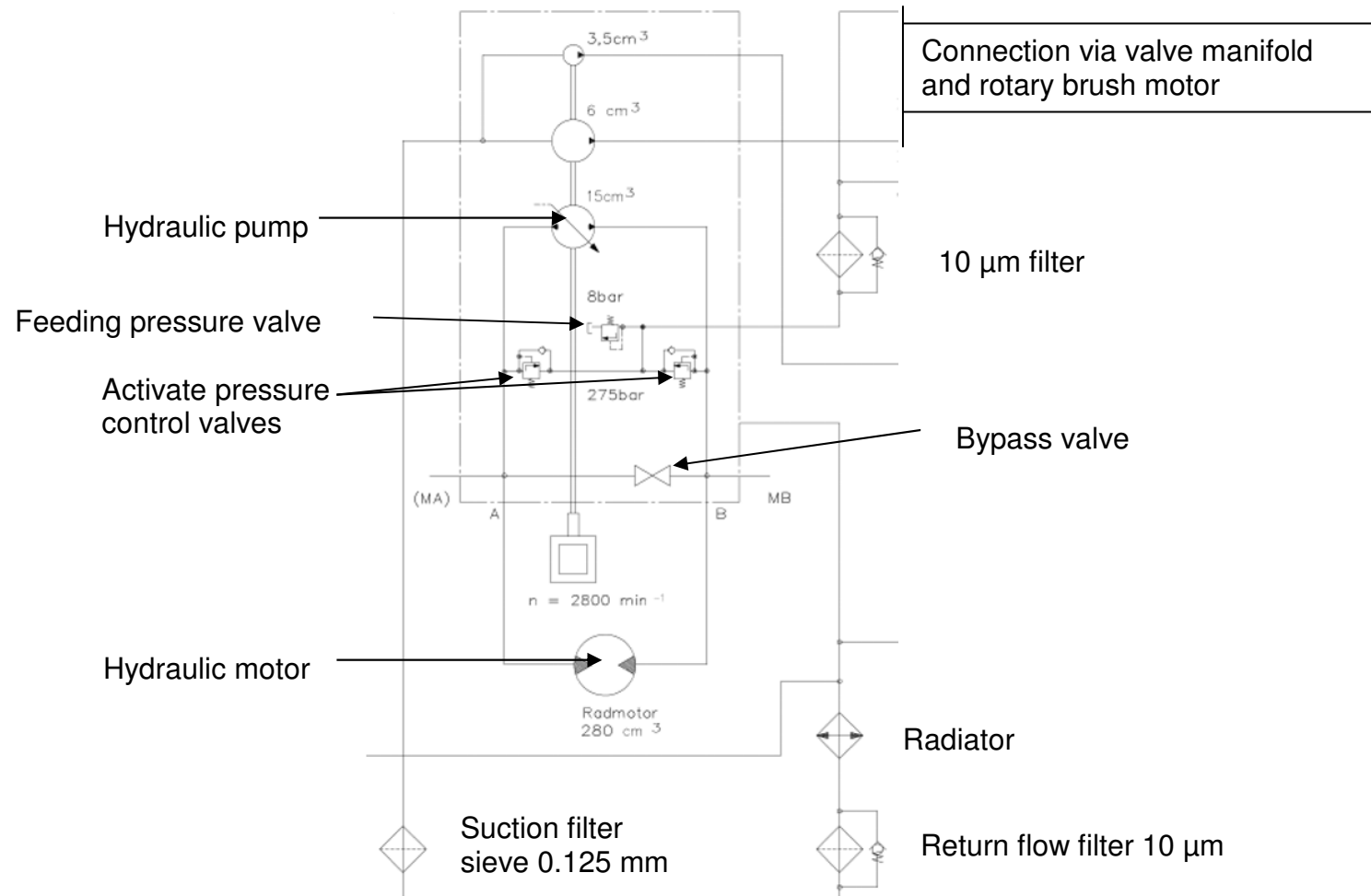

Hydrostatic operation:

When the engine is running, all the hydraulic pumps are automatically put into operation. The travel pump is in its neutral position, therefore there is no oil circulation (i.e. the hydraulic motor does not run). The gear pumps feed oil. The oil from working pump 1 flows through the valve manifold via the filter to the feeding supply connection. The pressure is set to 8 bar on the feeding pressure valve. The feed pressure can be measured at measuring point A and/or B (normally, there is only a measurement connection at B). If the pump is deflected in one direction via the accelerator at this point, it feeds oil. As a result of the oil circulation, the hydraulic motor is set to a rotating motion. Depending on the resistance against the rotation (rolling, friction, gradient resistance, etc.), a driving pressure is produced which can be measured at the measuring point. The maximum pressure while driving is set by means of a pressure control valve (PCV) There is a PCV for each driving direction set to 275 bar. If the vehicle needs to be towed, a bypass circulation must be opened for the hydraulic motor. This is performed by the bypass valve. The maximum forward speed (140 rpm) is set on the pump. In this case, the pump piston lever is extended to the speed at the same time the accelerator pedal is actuated to the stop. Now screw the pump connection to the pump piston lever. The reverse engine speed results from the kinematics. The neutral position is set mechanically using the “mechanical neutral position” screw (on the pump).

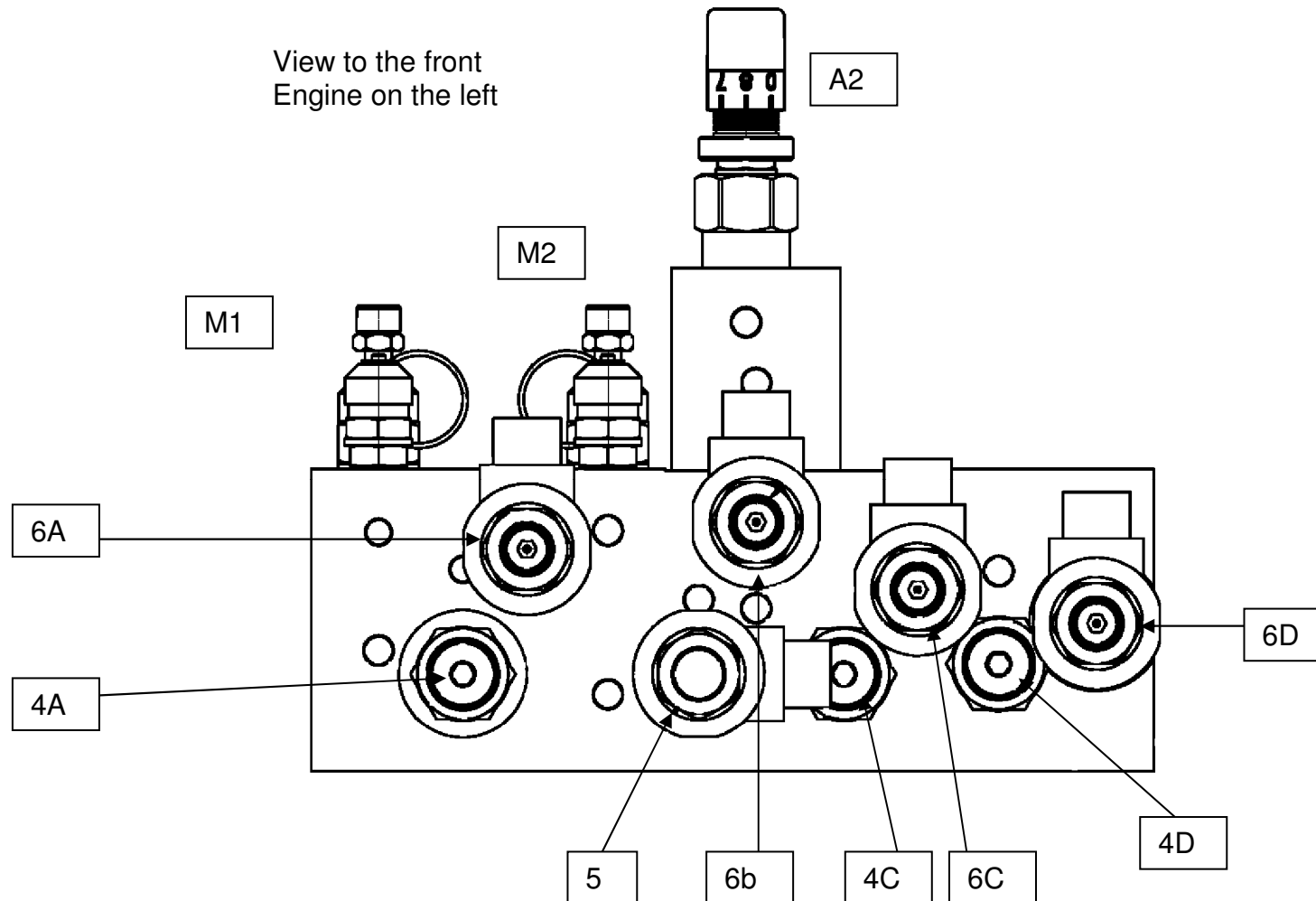

View to the rear
Engine on the right

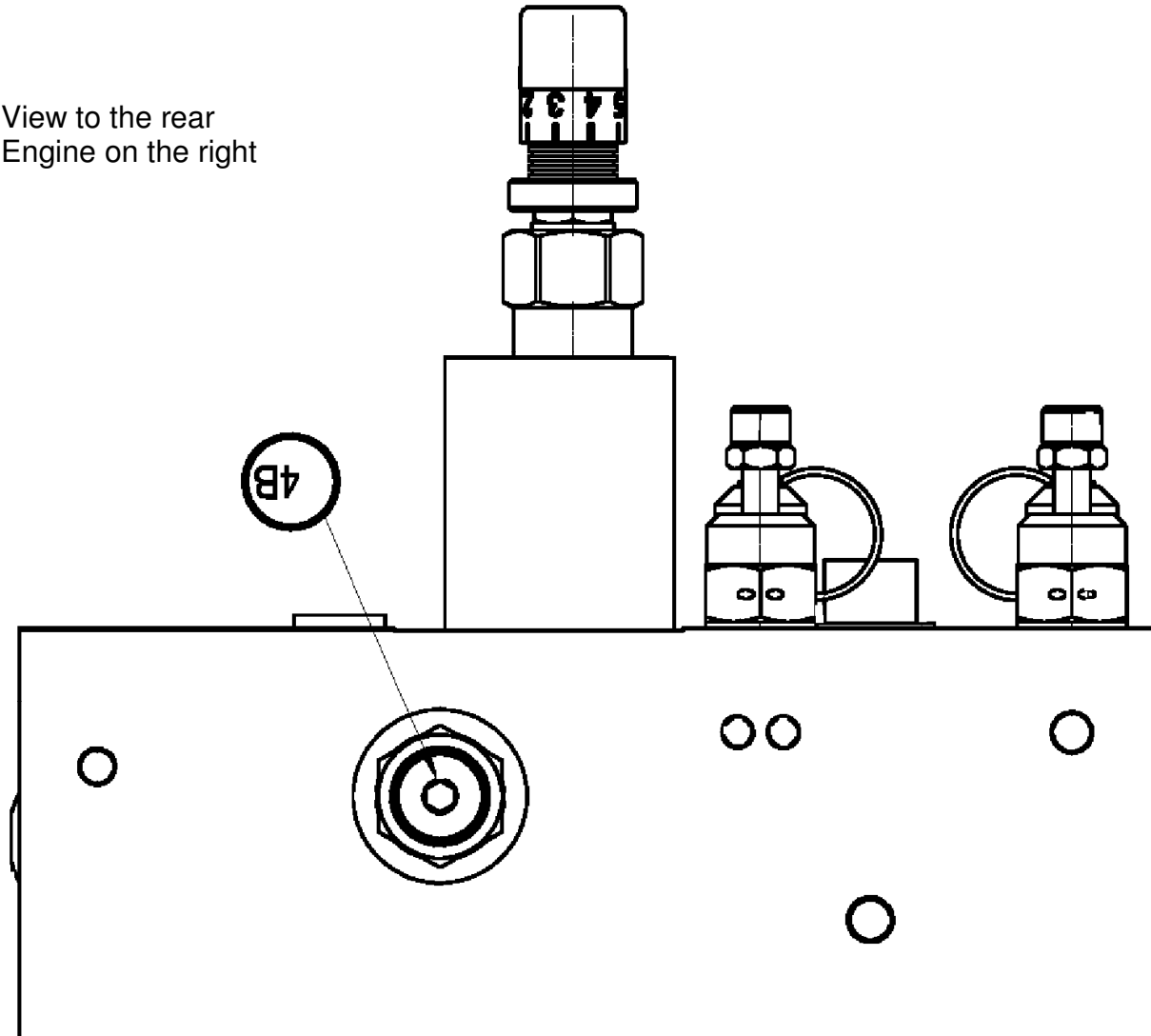

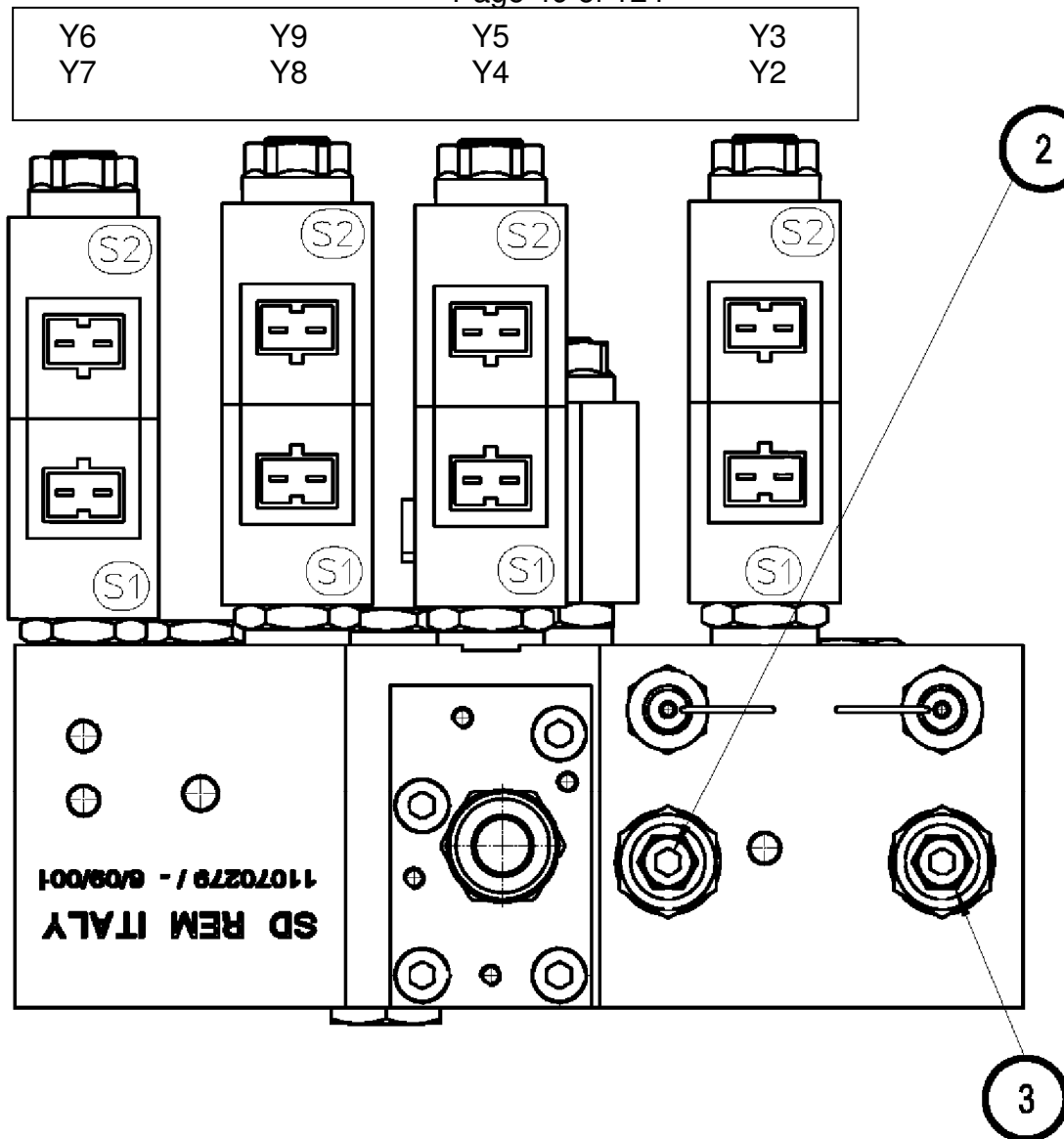

View from the top

Circuit diagram

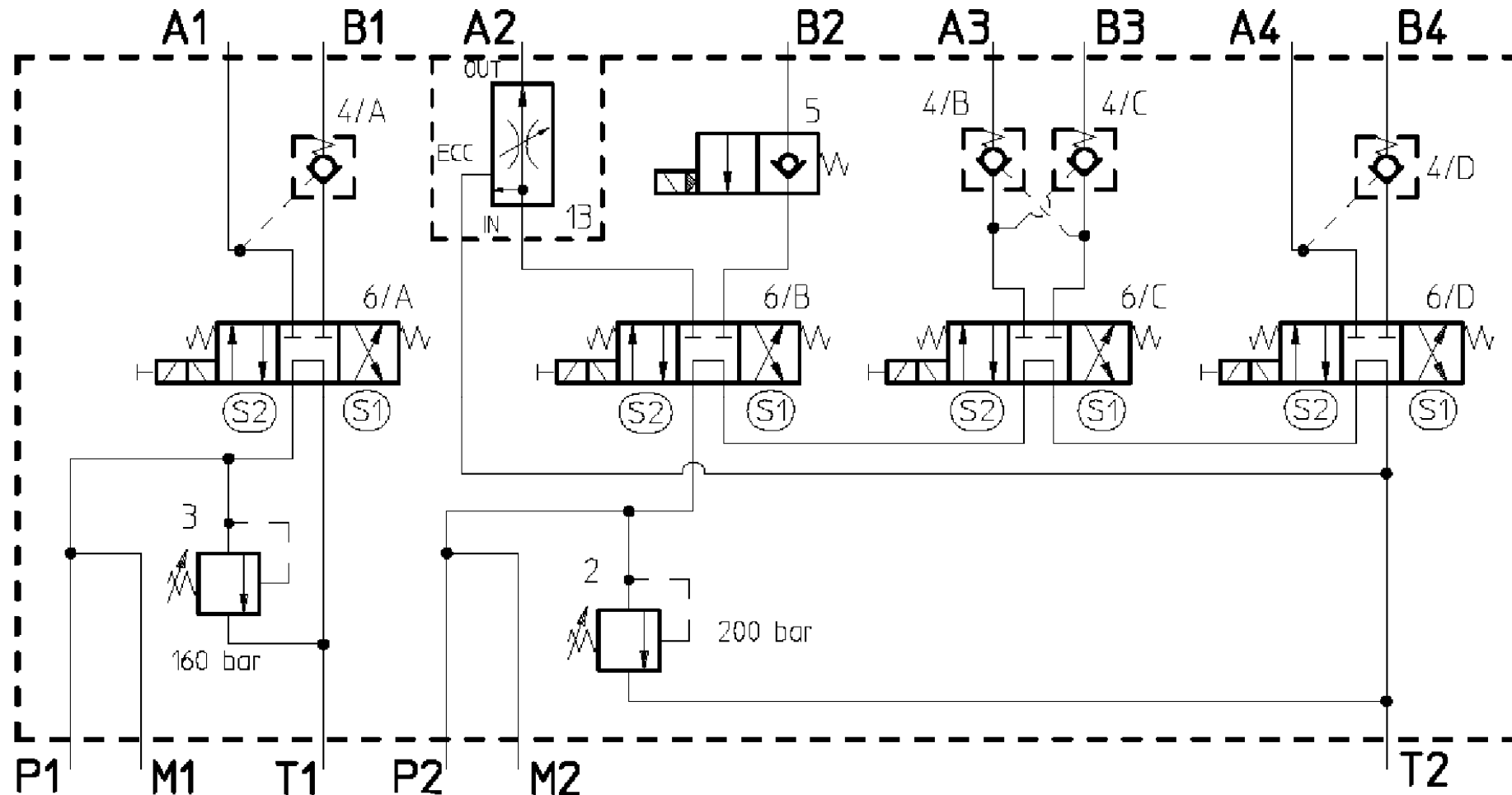

For position on the valve manifold, refer to drawing

Overview of functions

6/A S1	Rotary brush OFF and raise	Y2
6/A S2	Rotary brush ON and lower	Y3
6/B S1	Side brush OFF and raise	Y4
6/B S2	Side brush ON and lower	Y5
5	Enable lowering side brush	Y11
6/C S1	Lower hopper	Y8
6/C S2	Raise hopper	Y9
6/D S1	Pivot hopper out	Y7
6/D S2	Pivot hopper in	Y6

3.2 E hydraulics

3.2.1 General description

E model, short description

A fixed displacement pump driven by an electric motor feeds the necessary oil in an open circulation optionally to the brush lifting cylinders (rotary brush and side brush) or to the cylinder for emptying the dirt hopper. The lifting cylinders on the hopper arm are secured against falling by means of pipe-break protection.

E hydraulic pump

Gear pump with 1.2 cm³ displacement volume per revolution.

3.2.2 Valve manifold

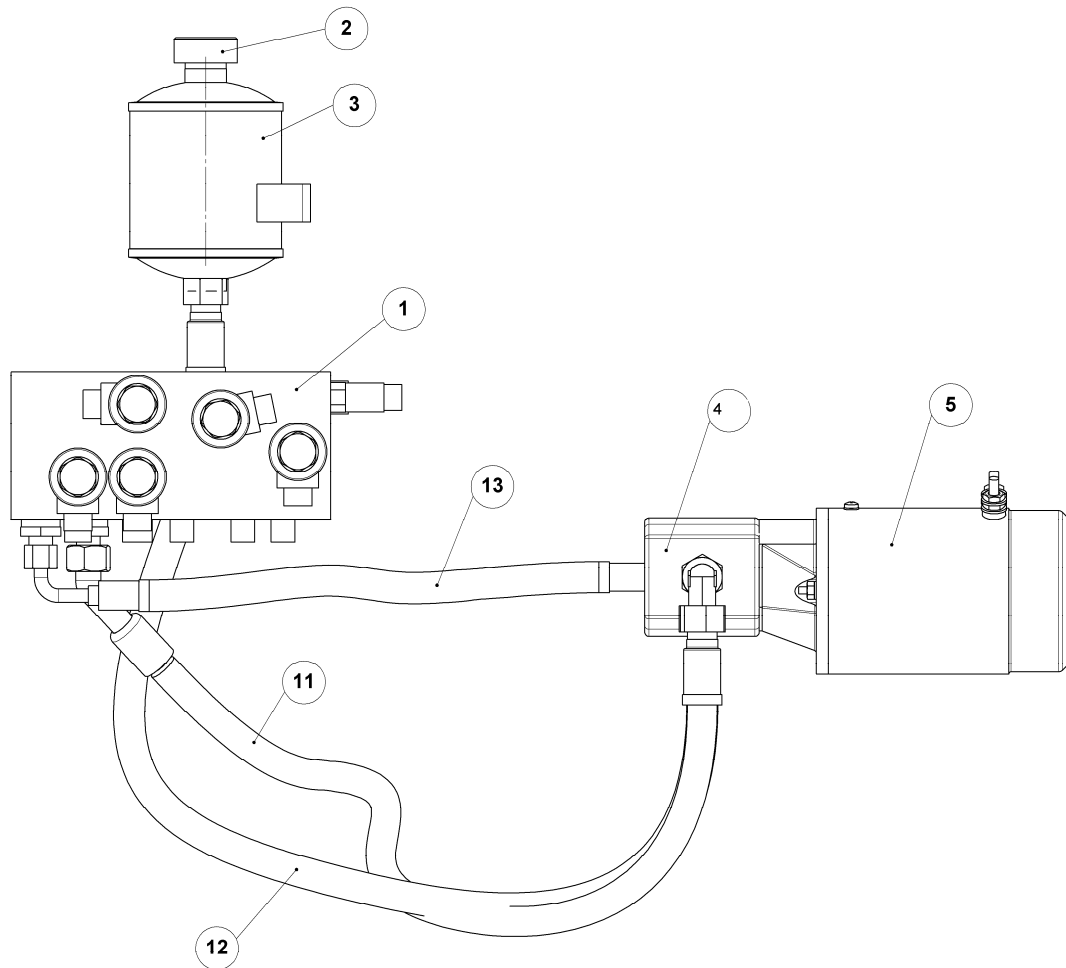

- | | |
|----|-----------------------------------|
| 1 | Main Valve |
| 2 | Cover with Dip Stick |
| 3 | Hydraulic Oil Tank |
| 4 | Pump |
| 5 | Electric Motor |
| 11 | Hydr. Hose Return from Main Valve |
| 12 | Hydr. Hose Pump – Main Valve |
| 13 | Hydr. Hose Tank - Pump |

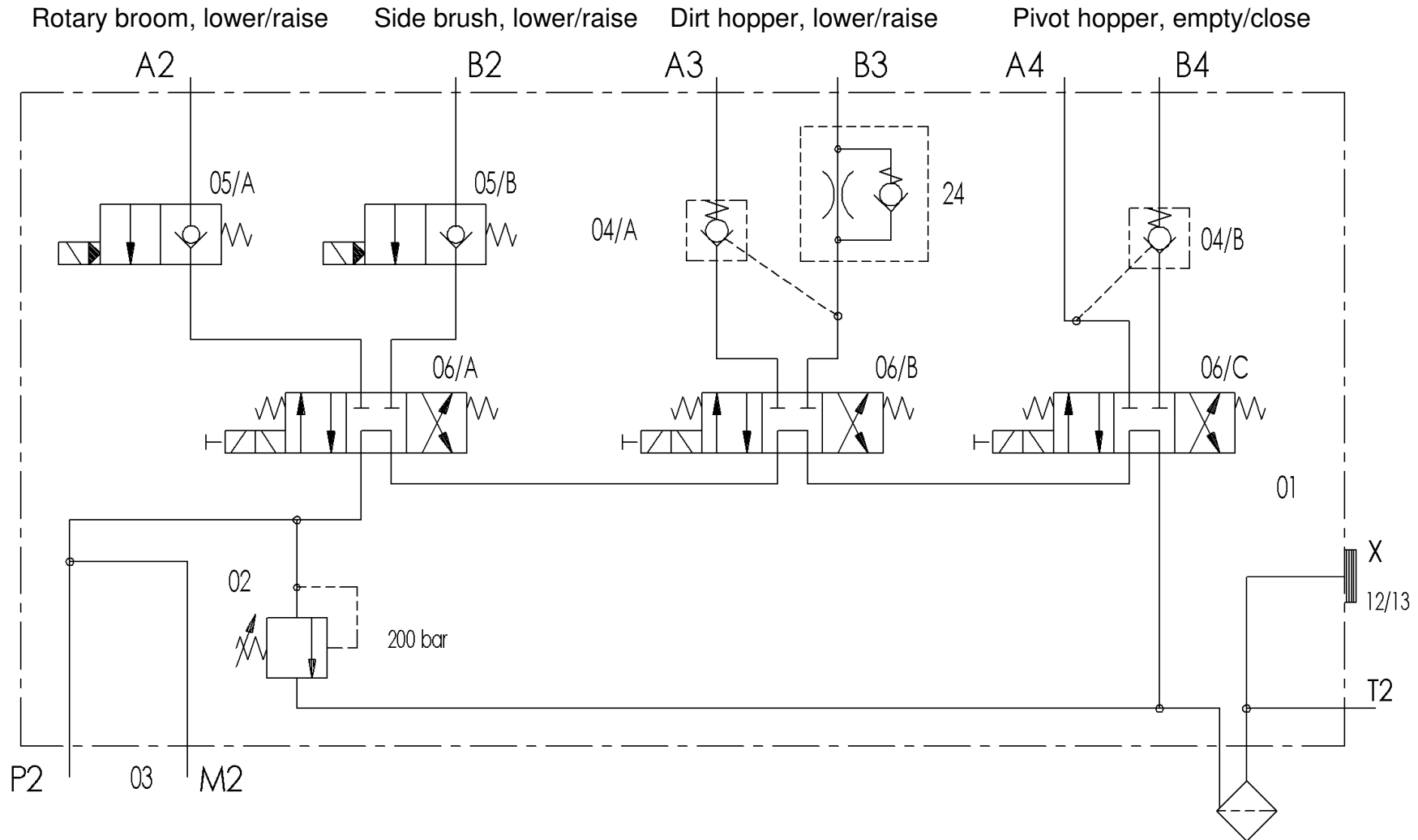

Component		Mainbroom		Sidebroom		Container			
		lower ↓	↑ lift	lower ↓	↑ lift	lift	lower	empty	zurück drehen
E-Motor Pump		0	t-on	0	t-on	1	1	1	1
Valve	Coil								
Ⓘ	-Y2	0	t-on	t-on	0	0	0	0	0
	-Y3	t-on	0	0	t-on	0	0	0	0
Ⓜ	-Y9	0	0	0	0	1	0	0	0
	-Y8	0	0	0	0	0	1	0	0
ⓂⓂ	-Y7	0	0	0	0	0	0	1	0
	-Y6	0	0	0	0	0	0	0	1
ⓂⓂⓂ	-Y4	t-on	0	0	0	0	0	0	0
ⓂⓂⓂⓂ	-Y5	0	0	t-on	0	0	0	0	0

t-on = Time controlled „ON“

0 = „OFF“

1 = „ON“

Service-Handbuch

Service Booklet

3.2.3 Venting

When venting the hydraulic unit, pay particular attention that no moisture, dirt or foreign bodies get into the system. The oil filled must be free of air pockets and be clean. Hydraulic oil: Mobil DTE 25 compliant with HLP - DIN 5124/Part 2 or equivalent.

- a) Move the dirt hopper to its home position (i.e. the hopper is lowered).
- b) Disassemble the T-piece from the hydraulic pump (the front connection when looking towards the front) and seal using closure plugs (Spare Part No. 01059630).



- c) Connect the suction end of the ventilation hose (SPN: 00492770) to the hydraulic pump. Insert the other end of the ventilation hose in the **completely filled** 10 l canister (SPN: 00112270). Position the canister on the floor to the right of the vehicle.
- d) Remove the lid from the hydraulic tank.
- e) Screw the second ventilation hose (SPN: 01059640) together with the threaded adapter (SPN: 01011830) on the opening left by the tank lid. Insert the other end of the second ventilation hose in the second, **empty** 10 l canister (SPN: 00112270) and also set it down to the right of the vehicle.

Note:

Insert the ventilation hose in the full canister sufficiently far so that the hose opening is considerably below the oil level of the canister but is not against the bottom of the canister. No air or oil mixed with air may be sucked up.

- f) Switch the main brush holding attachment and side brush holding attachment "On" and "Off" twice using the "Green" button.
- g) Switch the vehicle on and operate the hopper lift as follows:
- h) Raise the hopper to its maximum height,
- i) Pivot the hopper to its emptying position and back to its sweeping position; repeat the hopper pivoting process 4 times.
- j) Lower the hopper to its home position.
- k) Raise and lower the hopper but without pivoting the it; repeat the "raise/lower hopper without pivoting" process twice.

After completing the venting process, the hopper must be returned to its home position.

Venting the main brush holding attachment

- 1) Raise the main brush via the keypad.
 - 2) Disconnect the hydraulic lines from the main brush cylinder so that air can escape. The main brush lowers automatically.
Collect any escaping oil or oil/air mixtures in a suitable vessel or with cloths.
 - 3) Reconnect the hydraulic lines to the main brush cylinder firmly.
- Complete processes 1 to 3 once again.

Only when equipped with two side brushes, left/right

- 1) **Only** assemble the hydraulic test hose to the **left-hand** side brush measuring connection. The side brush is lowered. (If no measuring hose is available, the screw connection can be unscrewed).
- 2) Feed the hydraulic test hose to an empty container.
- 3) Use the diagnostics unit to activate raising the side brush (software number 2.3.3.1), i.e. the hydraulic pump and valve are switched on together.
- 4) Collect any oil escaping from the test hose or directly from the opened connection in a suitable vessel.
- 5) Switch off the pump and valve again using the diagnostics unit. Force the side brush piston rod against the stop with the applicable tool.
- 6) Disconnect the measuring hose and reconnect side brush connection firmly.

Note:

The hydraulic tank in the vehicle must not be emptied completely!
(Switch-on time < 8 sec). If the oil level is very low, refill with deaerated hydraulic oil!

Note:

If equipped with the optional *left-hand side brush*, pay attention to the special venting regulations!

Note:

(No continuous "knocking" noises may occur.)
Complete oil level and leak controls after the function test.

In the case of repairs to the hopper lift, a full ventilation must be performed, as described above. In the case of repairs to the main brush and side brush holding attachments, it is suffice to vent the main and side brush holding attachments.

Screw fit adapter Venting hose 1
With 12 L screw fit

Venting hose 1

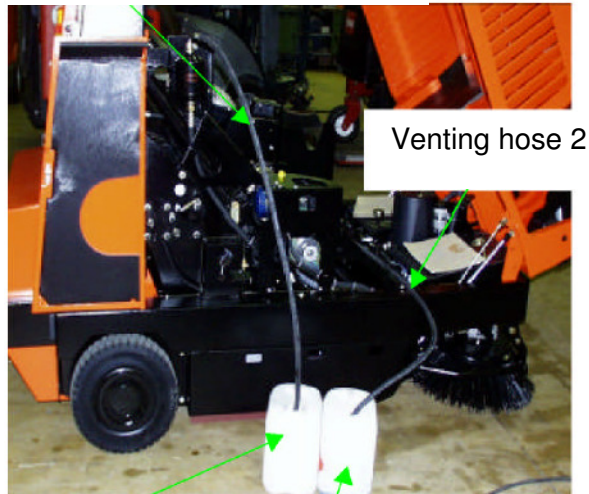

Filled with 10 l DTE 25
2 Pcs 10 l canister

EMPTY

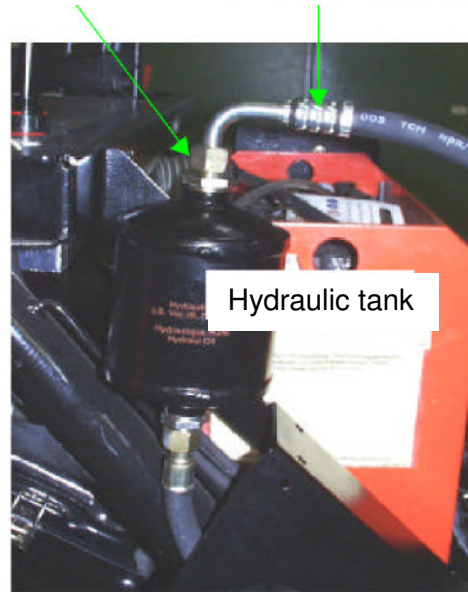

Venting hose 2 to fully filled hydraulic oil canister (10 l)

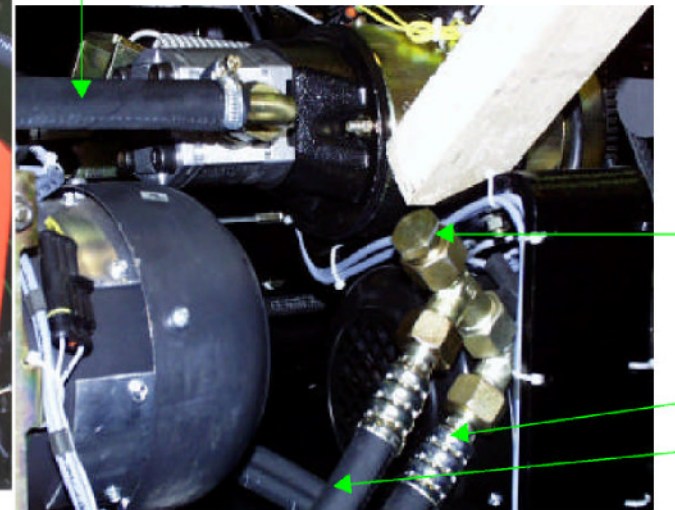

4.0 Electric System

General information

Attention!

- Always disconnect the battery (negative pole) when working on the engine and the electrical system.

Information on the alternator

- Only allow the engine to run when the battery is connected.
- Never use a charger as a cold start device.
- Disconnect the battery when recharging and completing electro-welding.

4.1 V/D electric system

4.1.1 Components

The module concept used for the J1450 is not applicable for the V/D models. The electric system operates by means of a main board (A1) which is installed underneath the left-hand operating panel.

Operating panel, left:



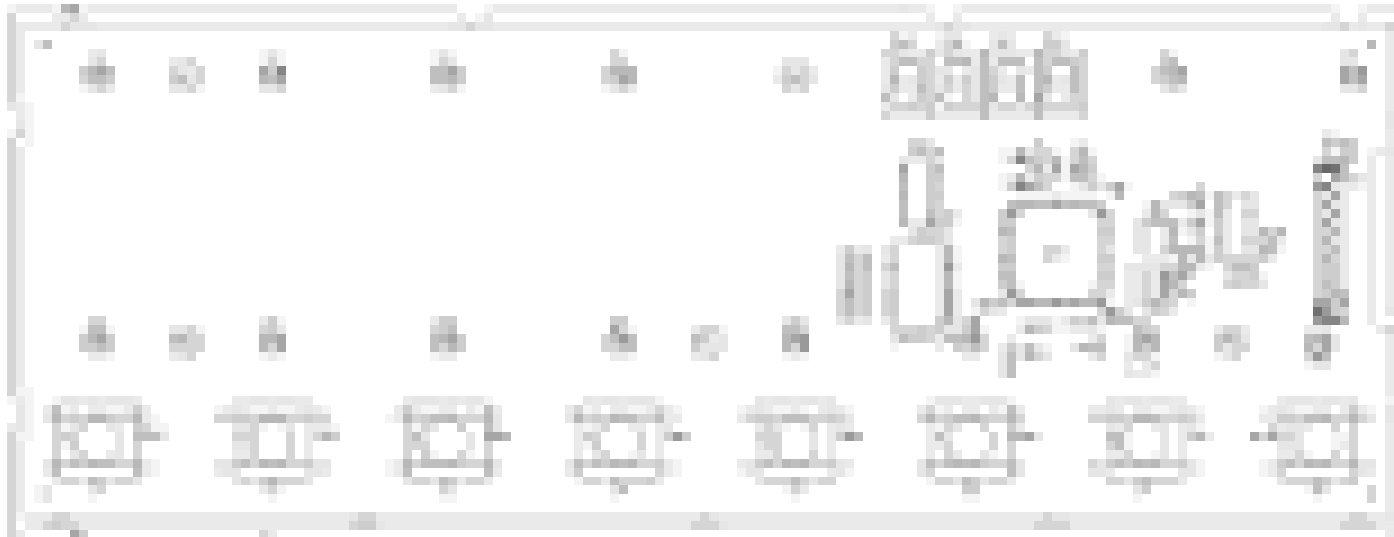

Board, top view

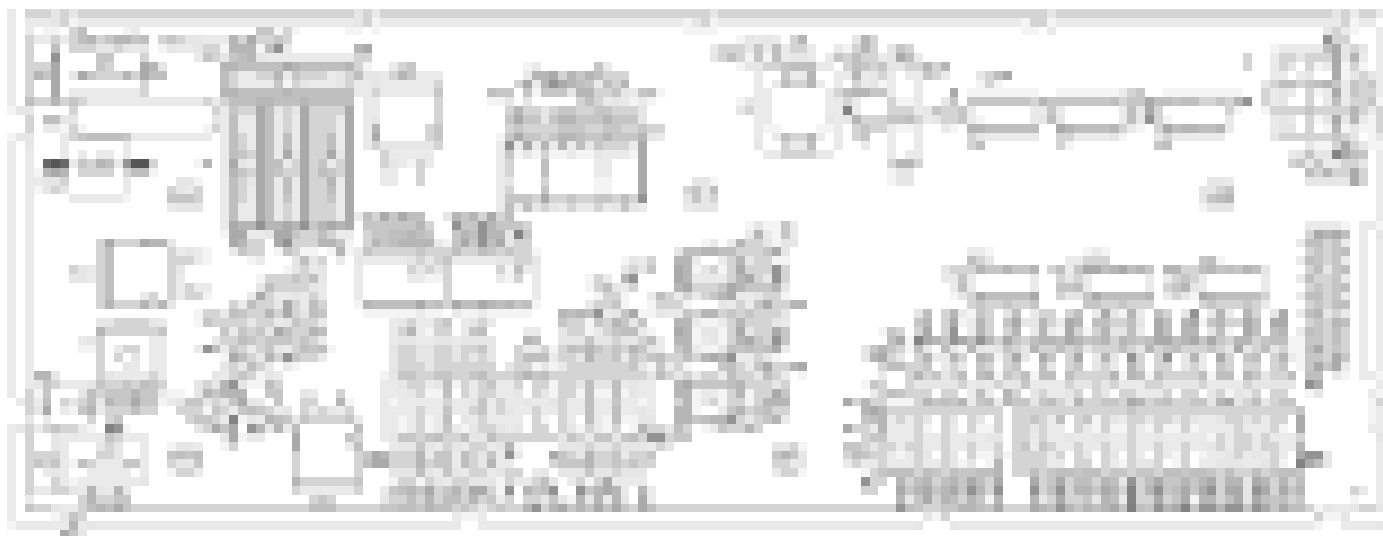

Board, bottom view

The switch plate, on which the switches and relays are mounted, is located underneath the right-hand operating panel.

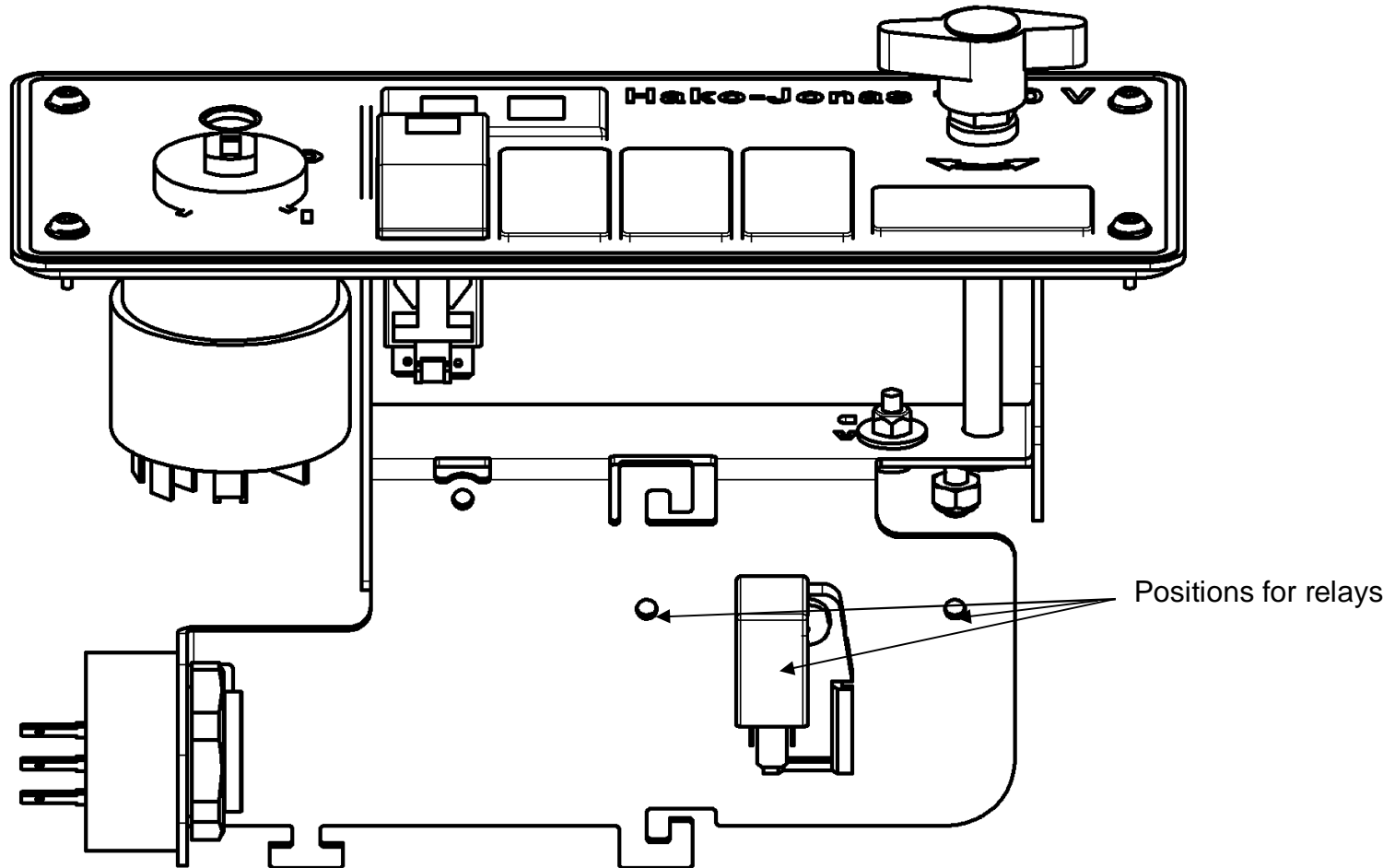

The fuse box is located in the right-hand area of the legroom (at knee height).

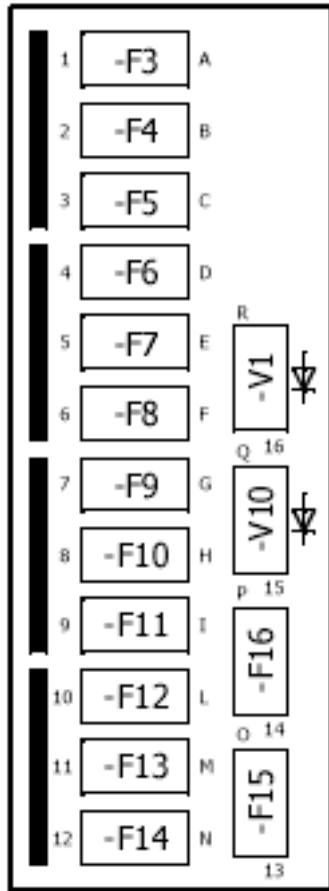

F3	15A	Lighting	Option
F4	10A	Hazard warning light	Option
F5	7.5A	Flashing beacon	Option
F6	30A	Heater, pre-fuse	Option
F7		Spare	
F8	15A	Engine stop relay	Diesel
F9	10A	Indicators	Option
F10	7.5A	Windscreen wipers	Option
F11	7.5A	2nd side brush	Option
F12		Spare	
F13	10A	Charge control	
F14	10A	Horn	
F15	5A	Parking/Rear light, left	Option
F16	5A	Parking/Rear light, right	Option

F1 50A Main fuse, diesel

F2 50A Pre-fuse, diesel

(They are located in the engine compartment in front of the battery.)

4.1.2 Configuration

All the electrical functions are controlled via the board. As with the J1450, various functions can be programmed. Configuration is possible in one of two ways. It can be completed directly on the vehicle using the left-hand operating panel or by using a diagnostics tool (Interace 03501750 and diagnose cable 03502110).

A "diagnostics connector" is required, Hako **SPN 03006790**, in order to complete the configuration using the operating panel. It is the same connector which is used on the B70CL and B90 (PIN2 to PIN3).

4.1.2.1 Accessing the configuration level

Specific conditions must be fulfilled when the vehicle is switched on in order to access the Configuration menu.

The menu can only be opened when "Read Only mode" is active. If settings are to be modified, the 6-pin diagnostics connector must be plugged into the rear side of the control unit. Only then is the user granted write access and permission to complete changes and save them.

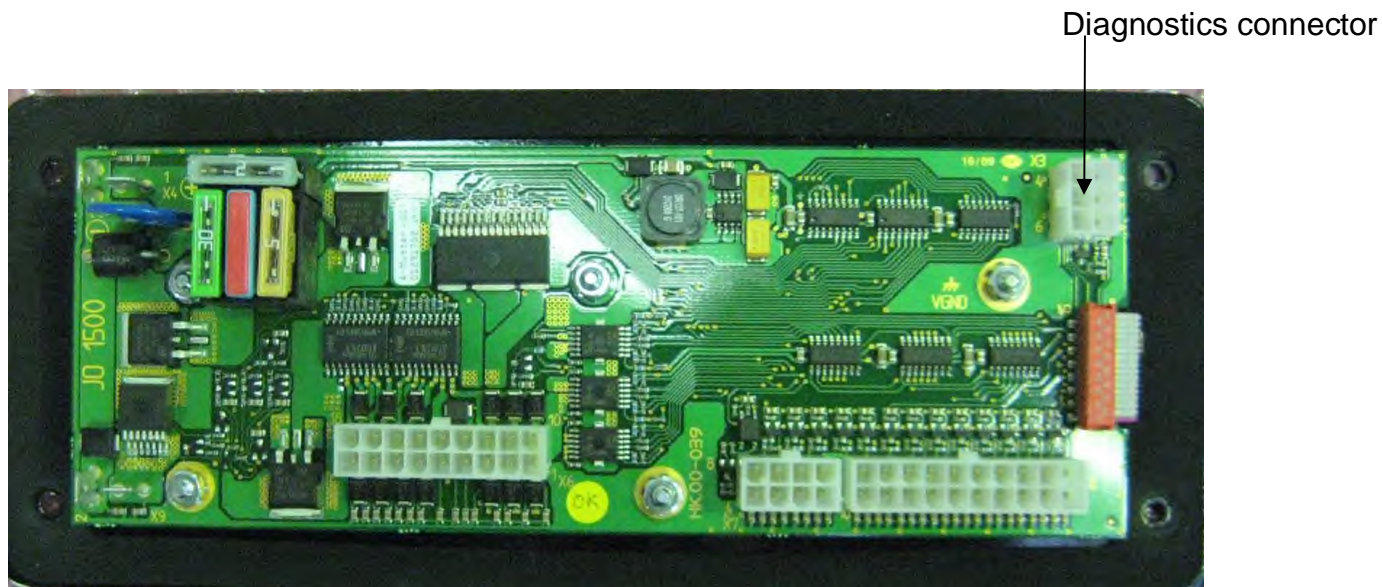

Press and hold the "Sweeping" and "Cleaning" buttons continuously for at least 3 seconds while the vehicle is being switched on via the key switch.

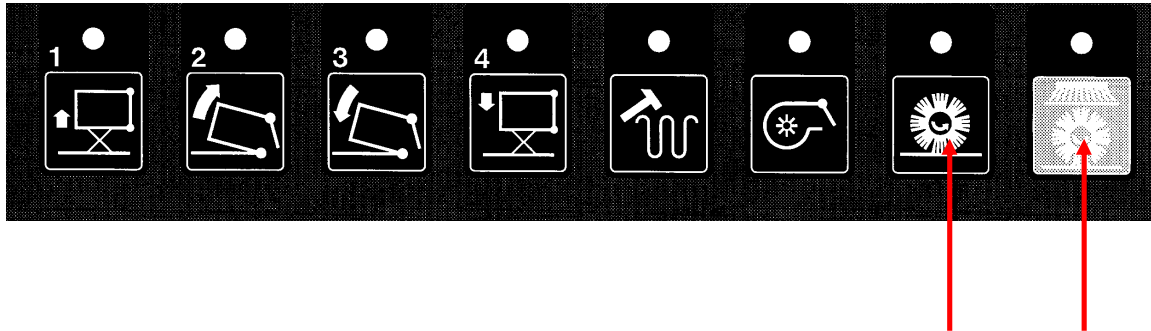

After accessing the menu, the following appears in the display:

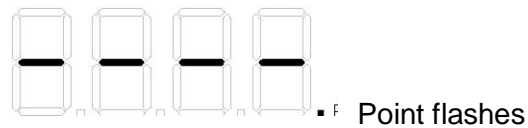

In the case of the Jonas 1500, menu guidance is provided by the "Raise dirt hopper (1)", "Pivot hopper out (2)" and "Clean (green)" buttons. The buttons are assigned as follows:

Function	Jonas 1500
<i>ChangeDigit</i>	Raise dirt hopper (1)
<i>ChangeValue</i>	Pivot hopper out (2)

Save	Clean (green button)
------	----------------------

ChangeDigit

Moves to the position in the display at which a value must be changed. The point flashes at the position currently selected. This button is used to switch between Chapter, Configuration and Content.

ChangeValue

Changes the value at the position selected using ChangeDigit. The value changes in ascending order, i.e. from 0..9 then A..F and back to 0. An exception here is the Chapter which changes from F to the last fault which occurred and then to ----. before switching to 0.

Values which are not applicable for the vehicle are skipped.

Save

After pressing this button for at least 3 seconds, the current Content setting is saved. When the Content has been saved, it is indicated by the point to the left of the Content. When the value for Chapter or Configuration is changed, the current Content is always displayed initially (the left-hand point beside the Content is on).

Example:

The FPV in **Chapter 2 , Configuration 1** should be changed from **1** to **2**:

Open the Configuration menu

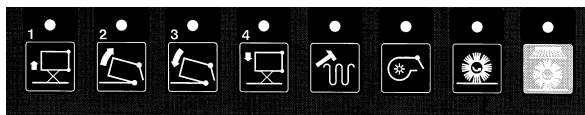
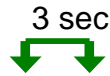

Display

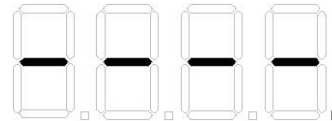

ChangeValue

Press three times. Chapter is now set to 2, the point beside Chapter flashes:

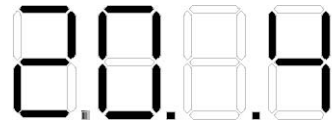
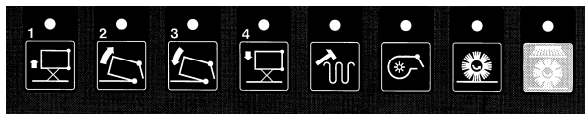

ChangeDigit

Press once. The point beside Configuration flashes:

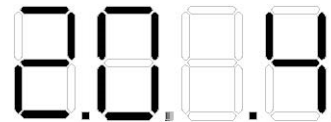
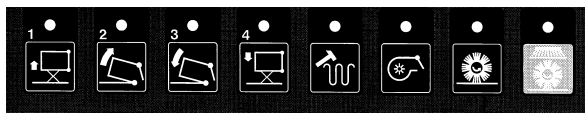

ChangeValue

Press once. Configuration is now set to 1, the current Content is 1:

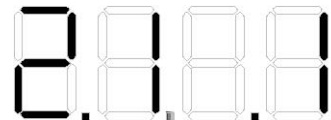

ChangeDigit

Press once. The point beside Content flashes:

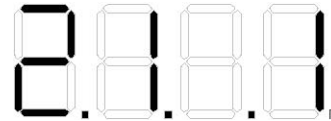

ChangeValue

Press once. Content changes to 2, the point to the left of Content goes out:

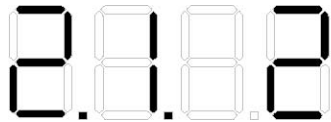
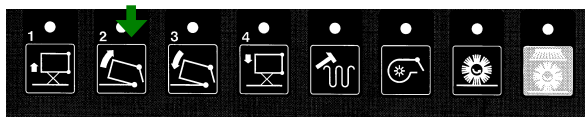

Save Press and hold for 3 sec. The point to the left of Content appears:



The value for Content is thus saved. Either exit from the menu by switching the vehicle off or continue to program other settings.

4.1.2.2 Configuration matrix

Chapter	Configuration	Content	Type	Description
0				Basic settings
0	0			Hardware identification
0	0	4		Control unit HK.00-039 (90567272)
0	1			Vehicle model
0	1	0		Prototype
0	1	1		J1500V
0	1	2		J1500D
0	1	3		J1500LPG
0	1	4		J1500 Bivalent
0	1	9		Service mode
0	2			Cleaning units
0	3			Battery settings
1				Options
1	0			Side brush, left (parallel operation to right)
1	0	0		Not available
1	0	1		Available
1	1			Hand-held vacuum hose
1	1	0		Not available
1	1	1		Available
2				Programmable program versions (PPV)
2	0			"Last error" display after switching on
2	0	0		Deactivate
2	0	1		Activate
2	1			Set home position after switching on (switch off all functions)
2	1	0		Never

Chapter	Configuration	Content	Type	Description
2	1	1		When green button is pressed
2	2			Seat switch delay
2	2	0		None
2	2	1		With programmed time
2	3			Dust vacuum on after shaking
2	3	0		Immediately
2	3	1		Standing; 10 sec delay
2	4			Shake filter (only adjustable when FPV#1 (3.0.1.) is set)
2	4	0		At intervals
2	4	1		As long as button is pressed
2	5			Automatic shaking prior to emptying (raise) (only with FPV#1)
2	5	0		Does not occur
2	5	1		Occurs
2	6			Automatic shaking after sweeping (only with FPV#1)
2	6	0		Does not occur
2	6	1		Occurs
2	7			Side brush, left, independent of right (only with FPV#1 and "Side brush, left" 1.0.1.)
2	7	0		Does not occur
2	7	1		Occurs
2	8			Error "3456" is suppressed (only with FPV#1)
2	8	0		Does not occur
2	8	1		Occurs
2	9			Deactivate sweeping during shaking (only with FPV#1)
2	9	0		Does not occur
2	9	1		Occurs
3				Fixed program versions (FPV)
3	0			FPV set
3	0	0		SOW version

Chapter	Configuration	Content	Type	Description
3	0	1		Refer to FPV table
3	0	2		Refer to FPV table
3	0	3		Refer to FPV table
3	0	4		Refer to FPV table
3	0	5		Refer to FPV table
3	0	6		Refer to FPV table
3	0	7		Refer to FPV table
3	0	8		Refer to FPV table
3	0	9		Refer to FPV table
3	1			SOW: Shake as long as button is pressed
3	1	0		No
3	1	1		Yes
3	1			SOW: Automatic shaking prior to emptying (raise)
3	2	0		No
3	2	1		Yes
3	3			SOW: Automatic shaking after sweeping
3	3	0		No
3	3	1		Yes
3	4			SOW: Filter vacuum on together with sweeping
3	4	0		No
3	4	1		Yes
3	5			SOW: Sweeping deactivated as long as filter vacuum is on
3	5	0		No
3	5	1		Yes
4				Parameters
4	0			Seat switch delay
4	0	0		0.5 s
4	0	1		1.0 s

Chapter	Configuration	Content	Type	Description
4	0	2		1.5 s
4	0	3		2.0 s
4	0	4		2.5 s
4	0	5		3.0 s
4	0	6		3.5 s
4	0	7		4.0 s
4	0	8		4.5 s
4	0	9		5.0 s
4	1			Preheating (LED in display unit)
4	1	0		5 s
4	1	1		10 s
4	1	2		15 s
4	1	3		20 s
4	1	4		25 s
4	1	5		30 s
4	2			Close fuel valve when engine is not started
4	2	0		5 s
4	2	1		10 s
4	2	2		15 s
4	2	3		20 s
4	2	4		25 s
4	2	5		30 s
4	2	6		35 s
4	2	7		40 s
4	2	8		45 s
4	2	9		50 s
F				Last error Delete by pressing green button for 3 sec

Menu content which is not relevant is not displayed

4.1.2.3 FPV table

	FPV#0	FPV#1	FPV#2	FPV#3	FPV#4	FPV#5	FPV#6	FPV#7	FPV#8	FPV#9
Shake as long as button is pressed	SOW	0	1	0	0	1	0	0	0	
Automatic shaking prior to emptying (raise)	SOW	0	0	1	0	0	1	0	0	
Automatic shaking after sweeping	SOW	0	0	0	1	0	0	1	1	
Filter vacuum on together with sweeping	SOW	1	1	1	1	0	0	0	1	
Sweeping off as long as shaking is active	SOW	0	0	0	0	0	0	0	1	

4.1.3 Error messages

Errors are detected because various inputs and outputs are monitored by the board. These error messages are shown in the display.

Display code	Description	Measure
2263	Hydraulic valve, main rotary brush , "Raise/Lower/On/Off" (overloaded, defective or not connected)	Check hydraulic valve Y2/Y3 Ignition key off/on Restart V-engine
2366	Hydraulic valve, right-hand side brush, lower/on (overloaded, defective or not connected)	Check hydraulic valve Y5,11 Ignition key off/on Restart V-engine
2367	Hydraulic valve, right-hand side brush, raise/off (overloaded, defective or not connected)	Check hydraulic valve Y4 Ignition key off/on Restart V-engine
2461	Lifting element for belt tension clutch, dust vacuum (overloaded, defective or not connected)	Check lifting unit M5 Ignition key off/on Restart V-engine
2561	Agitating motor (overloaded or not connected)	Check agitating motor Ignition key off/on Restart V-engine

2661	Turn hydraulic valve for dirt hopper (overloaded, defective or not connected)	Check hydraulic valve Y7/Y6 Ignition key off/on Restart V-engine
2662	Hydraulic valve for dirt hopper, "Raise/Lower" (overloaded, defective or not connected)	Check hydraulic valve Y9/Y8 Ignition key off/on Restart V-engine
316A	Safety fuse F3 defective (hydraulic valves, fuel supply, starter release)	Change fuse Ignition key off/on
316C	Safety fuse F4 defective (belt tension clutch, dust vacuum)	Change fuse Ignition key off/on
316E	Safety fuse F2 defective (agitating motor)	Change fuse Ignition key off/on
3351	Hydraulic oil too hot (only shown in failure list)	Check hydraulic cooler and switch S10
3361	Buzzer (overloaded, defective or not connected)	Check buzzer Ignition key off/on Restart V-engine
3456	V-engine stopped (e.g. stalled) (generator does not supply charge voltage) Cleaning units were activated without the V-engine running reliably	Check charge voltage Ignition key off/on Restart engine
3643	Starter and fuel valve inhibited, i.e. timeout for engine start	Ignition key off/on Restart V-engine

3661	<p>Fuel valve (with gasoline/LPG) (overloaded, defective or not connected)</p> <p>Stop engine signal (with diesel) (overloaded, defective or not connected)</p>	<p>In the case of gasoline/LPG Check fuel valve Ignition key off/on Restart V-engine</p> <p>In the case of diesel Check control relay K10 Check actuator Y1 (engine stop)</p> <p>Ignition key off/on Restart V-engine</p>
3662	<p>Auxiliary relay, starter release K1 (overloaded, defective or not connected)</p>	<p>Check relay K1 Ignition key off/on Restart V-engine</p>
3663	<p>Timeout accelerator pedal, neutral position detection, i.e. no actuation of the accelerator pedal over a longer period.</p>	<p>Accelerator pedal position detector defective or manipulated</p> <p>Ignition key off/on Set accelerator pedal to neutral position Restart V-engine</p>
3664	<p>Timeout, seat contact i.e. no driver detected on the seat for a longer period</p>	<p>Seat contact has been manipulated or is defective</p> <p>Ignition key off/on Actuate seat contact Ignition key off/on Restart V-engine</p>
2368 + 2369	<p><i>SOW only, SB independent of right</i> Hydraulic valve, left-hand side brush, lower (overloaded, defective or not connected)</p>	<p>Check hydraulic valve Y17 or Y15</p> <p>Ignition key off/on Restart V-engine</p>

4.2 E electric system

Attention!

All work on the vehicle may only be completed after disconnection of the power supply (disconnect the battery plug) with the exception of the current and voltage measurements.

When changing high current fuses, only loosen the screws. Never unscrew the screws completely, otherwise there is a risk of a short circuit.

Insert the new high current fuses fully, i.e. evenly under the screws.

Following repairs, the starting current and operating current must be measured in order to discover any potential faults.

The legally binding, generally applicable safety and accident prevention regulations must be observed when performing any work on the vehicles.

4.2.1 General Information

The Hako-Jonas 1500E is provided with a Service indicator in the display of the operating hour counter. After switching on the key switch, a four-digit number appears for approx. 1 second which identifies the software version (e.g. 3.019), possibly followed by another four-digit number (for approx. 2 seconds) which indicates the last fault which occurred (e.g. 2.2.5.1.) and finally the operating hour counter (e.g. 0007.). At the same time the operating hour counter appears, the battery charge indicator also appears.

When an error occurs, the red LED lights up, indicating a defect, and the vehicle issues an acoustic signal. The current diagnostic code is displayed (four-digit number in the Service indicator) with flashing points between the digits. Only when these criteria are fulfilled is the error currently pending!
The diagnostic code broken down in the table.

Abbreviations used in this chapter:

LDS – Low discharge signal transducer
FPV – Fixed program version
PPV – Programmable program version

Validity of the descriptions

The explanations provided in the following chapters apply to vehicles with software version 3.019 or later.

4.2.2 Settings and programming the vehicle

Control electronics/Operating panel settings which must be defined and checked on every vehicle

(Setting 1):

Vehicle model (E)
Options (left-hand side brush, side brush speed adjuster)
TSG or battery selection
Deletion of the display of the last error on completion of repairs

Settings for the fixed program version (FPV) using the operating panel

(Setting 2):

- Behavior of the shaking device and filter vacuum in accordance with the cleaning units.

Settings of the programmable program version (PPV) which can be defined according to customer requirements using the operating panel

(Setting 3):

Display the last (cleared) error after switching the vehicle on
Activate the basic setting after switching on
Seat switch delay
Switch sweeping off automatically prior to shaking
Filter vacuum on after shaking
Shake filter
Automatic shaking prior to emptying (raise)
Automatic shaking after sweeping/program

Setting the shaking intervals

(Switching 4):

Note: Normally, it is not necessary to set the shaking interval or to modify it. The interval only needs to be adapted in the case of extreme working conditions. If set incorrectly, it can lead to malfunction of the filter system

Setting module 3 (Code A and Code B):

DIP switch for electronic safety and module coding

4.2.2.1 Short description

The vehicle is controlled by means of the following electronics:

- Control unit (-A1)
- Module 3 Code A (-A2)
- Module 3 Code B (-A3)
- Auxiliary power supply module (voltage converter 36V/24V)
- Operating panel
- Drive control (-A6)
- Speed adjustment, right-hand side brush
- Speed adjustment, left-hand side brush (with left-hand side brush option)

Power is supplied to the electronic systems via the auxiliary power supply module, a voltage converter from 36 V to 24 V. Since the electronic systems are also installed in the Hakomatic B900, it relates to 24 V electronics so that the voltage in the Jonas 1500E must be converted. Components such as motors and pumps etc. remain 36 V components.

The control electronics assumes all the control and monitoring tasks in the vehicle except for the drive control.

The drive control operates independent of the other electronics, only the enable signal and the signal to the reduce speed are sent to the drive control via the control electronics. Also, a signal is sent from the drive control to the control electronics for forward and reverse drive.

No diagnostic code is issued in the event of a defect in the drive control because the drive control has its own diagnostics display. (Refer to Chapter 10 for more information.)

Switching between the buttons for the rotary brush and green button (for simultaneous activation/deactivation of the rotary brush, side brush and suction ventilator) can be performed at any time so that the respective function required is always active. The extractor fan button can be switch on and off regardless of the cleaning mode selected.

For safety reasons, the vehicle is equipped with a seat contact switch. This can also be programmed to stop the vehicle following a delay (refer to Setting 3 or PPV). The selection, whether preventing vehicle stoppage is immediate or following a delay, depends on the customer's requirements or area of application (e.g. in the case of extremely uneven ground where the driver may briefly lose contact with the seat, the vehicle should not be set to stop immediately). If the delay function is deactivated (refer to Setting 3 or PPV), the seat switch must be continuously actuated, i.e. leaving the vehicle seat with the vehicle key switch switched on stops the vehicle immediately.

In the same way, the parking brake must be released in order to enable the cleaning functions and drive control.

Vacuuming off

The vacuum is switched off by the operator by means of a button when vacuuming is inappropriate. This is necessary in the case of damp waste, for example, because this would not only soil the filter element heavily but also impair its function (air flow volume) and possibly damage it beyond repair. In addition, the filter element would not be cleaned very efficiently by shaking.

Basic setting of the vehicle / releasing/inhibiting functions

After switching the vehicle on, all the components move to their "home position" when the seat switch is actuated.

This means that the control electronics control all the components (lifting elements and motors).

The lifting elements are raised as long as they have not been switched off by the microswitch monitoring the top end position integrated in the lifting element. The motors are switched off and the LED indicators in the cleaning component operating panel go out. The drive control receives the enable signal.

If the seat switch is not actuated, all the motors are also switched off but the lifting elements are not raised, for reasons of safety, and the drive control is not enabled.

If the parking brake is applied, the cleaning functions are disabled and the red LED for "Brake applied" lights up. This switch is also a normally closed contact so, therefore, in the case of a malfunction, check the switch and all the cable connections and connectors. If the parking brake is applied and the driving direction selection switch is actuated (forward or reverse), a warning signal is issued from a buzzer.

On pressing the rotary brush button, only the rotary brush is switched on or off and the side brush switched off, or it is switched off together with the extractor fan.

4.2.2.2 Setting 1:

Vehicle model, options, LDS/battery selection, deleting the indicator for the last error

It is essential to check the settings described in this section and to readjust them when necessary. Particularly then when the electronic system has been changed. This setting configures the electronic system specifically for the vehicle.

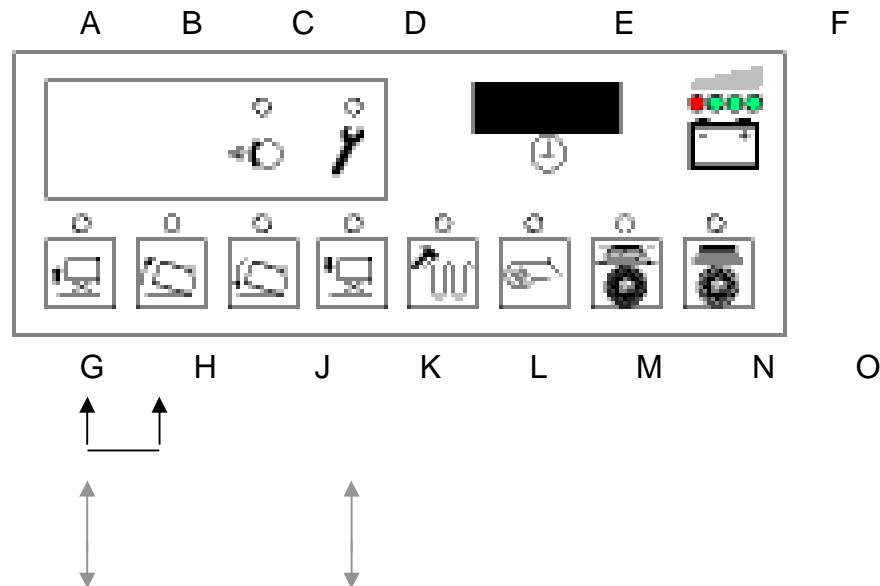

Accessing the programming function

Switch off the vehicle using the key switch.

Press and hold the buttons "G" and "H" simultaneously and then switch the key switch on.

Keep both buttons pressed until the display in the operating hour counter changes (initially shows the software version), then release both buttons.

The indicator for the vehicle model set up appears automatically. Press button "G" to open the display for the options set, press again to display the LDS setting display and press again to display the last (cleared) error. Press button "K" to skip one display back with each press.

Exit from the programming function at any time by switching off the key switch.

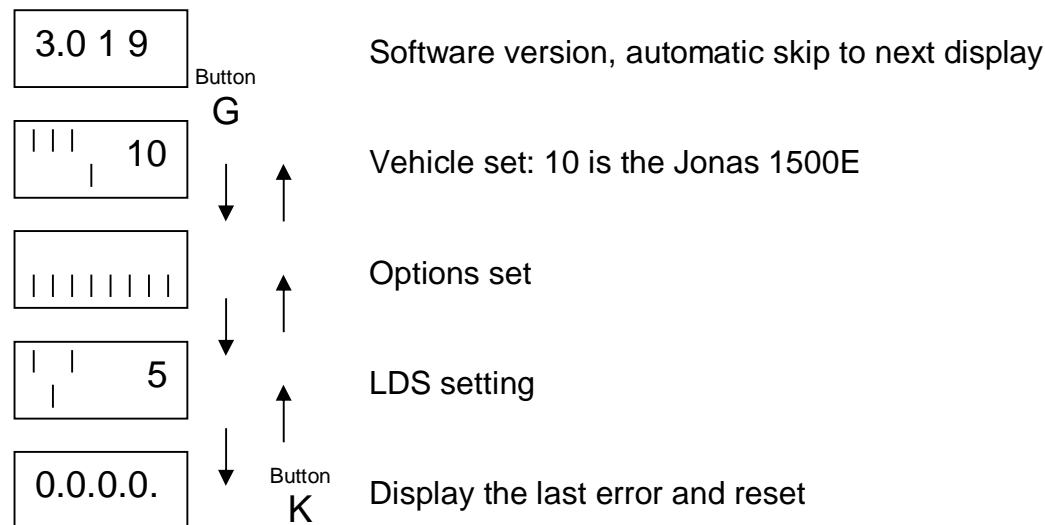

Control and vehicle type setting

Control electronics (schematic diagram)

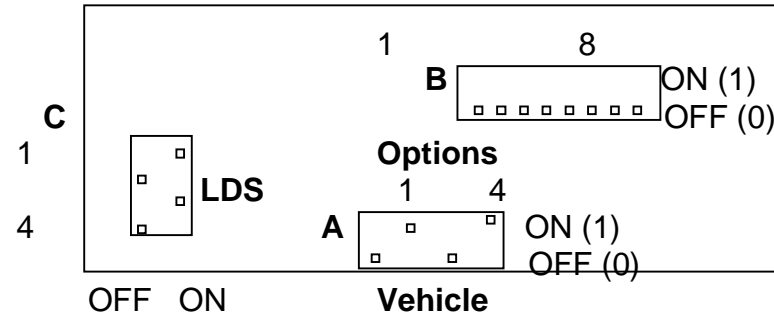

The vehicle type, at least, must be set correctly. This is done using DIP switch A on the control electronics. (Refer to above diagram.) With regard to the Jonas 1500E, the bar nos. 1 and 3 must be set to "ON" and bar no. 2 and 4 to "OFF". The number "7" appears in the operating panel in the display.

If the switch settings do not comply with the data displayed, set the correct DIP switch settings.

Jonas 1500E 1: OFF
 2: ON
 3: OFF
 4: ON

Control and option settings

Each vehicle option must be set on DIP switch B (refer to above diagram) on the control electronics.
Only the following options are available for the Jonas 1500E

- | | | |
|----|-----------------------|---------------------------|
| 1: | <i>Not applicable</i> | (Default setting = "OFF") |
| 2: | <i>Not applicable</i> | (Default setting = "OFF") |
| 3: | Side brush, left | (If available = "ON") |
| 4: | <i>Not applicable</i> | (Default setting = "OFF") |
| 5: | <i>Not applicable</i> | (Default setting = "OFF") |
| 6: | Side brush speed | (If available = "ON") |
| 7: | <i>Not applicable</i> | (Default setting = "OFF") |
| 8: | <i>Not applicable</i> | (Default setting = "OFF") |

The option is only activated when the DIP switch is set to ON.

Control and LDS setting

It is essential that the LDS (total discharge signal transducer) is set to the correct battery types.

If different batteries are installed, the LDS setting must be altered as described below. DIP switch C on the control electronics must be used in this case (refer to the Figure on Page 21)

DIP switch 4 must be set to 36 V.

The total discharge signal transducer must be set according to the following table. (No. 5 is the default setting.)

Digits in the display →	2	3	4	5	6	7	
DIP switch	GIS external	GIS	PzS external	PzS	Gel; GiV (Sonnenschein)	Gel; PzV (Deta)	
1	0	1	0	1	0	1	
2	1	1	0	0	1	1	
3	0	0	1	1	1	1	
4	OFF = 36 V						

"1" signifies ON; "0" signifies OFF

"External" refers to the batteries that were **not** supplied by **Hako**.

Reset voltage: Approx. **38.5 V**.

Attention: In the case of maintenance-free gel batteries, a distinction is no longer made between Sunshine and Deta batteries; the setting is oriented according to the battery types. Setting 6 for GiV batteries and setting 7 for PzV batteries, regardless of the manufacturer. (Due to the history, references remain Sonnenschein and Deta in the documents.)

Viewing and deleting the last diagnostic code which occurred from the display

Viewing

Press button "G" three times; the four-digit diagnostic code appears with flashing points (last error which occurred and was cleared)
Exit from the program by turning the key switch to OFF (do not do this the system is currently switching to the "Delete" option).

Deleting

Press and hold button "O" until the display changes to 0.0.0.0.

Release the button, switch the key switch to OFF and switch it on again.

The software version appears first and then changes to the normal operating hour counter.

The last error which occurred can be read out from the memory at any time, as described in "Viewing", and viewed because the diagnostic code is retained there.

Exit from the program by turning the key switch to OFF.

4.2.2.3 Setting 2:

Settings of the fixed program version (FPV) using the operating panel (control and adjustment)

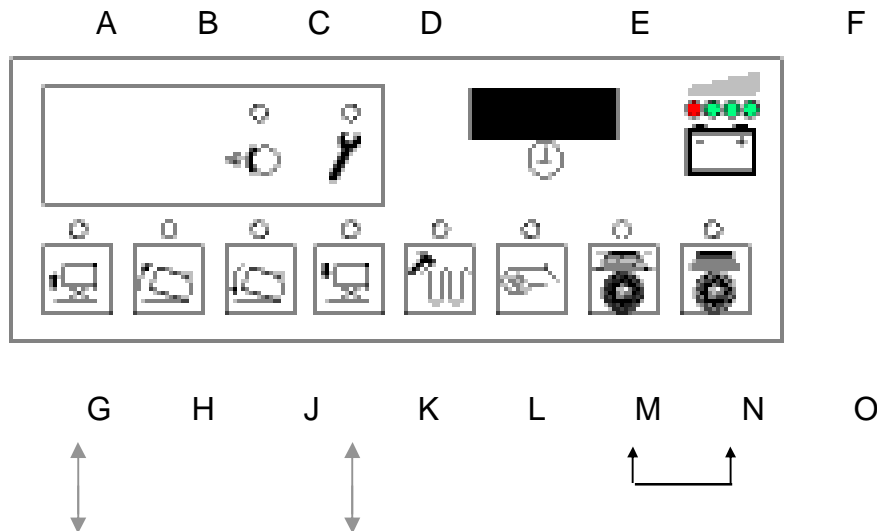

Control

Switch off the vehicle using the key switch.

Press and hold the buttons "N" and "O" simultaneously and then switch the key switch on.

Keep both buttons pressed until the display of the software version is replaced by a digit and then release both buttons.

Example:



The various programs can be selected using the buttons "G" (scroll forward in the sequence of digits) and "K" (scroll backwards in the sequence of digits).

The program which is active is assigned a dash preceding the digit.

Example:

-	4
---	---

 (recommended setting for Jonas 1500E)

Exit from the program by turning the key switch to OFF (do not do this you want to activate the "Setting" option).

Setting

Use the button "G" or "K" to select the required program.

Press and hold button "O" until a dash appears in front of the digit. The program is now saved and active.

Exit from the program by turning the key switch to OFF.

Content of the fixed program versions (FPV):

Setting up the FPV includes programming the green button on the operating panel (button "O") as well as automatic function procedures for the vehicle which must be set according to individual customer requirements. The behavior of the shaking device and the filter vacuum in dependence on the cleaning units can be set up here. The various functions are listed in the following table. A condition for certain functions is that the corresponding settings are activated (refer to Setting 3 (PPV)).

FPV (fixed program versions):

Version	Function
1	<ul style="list-style-type: none"> - Filter vacuum is switched on with sweeping/program; - No manual shaking as long as button remains pressed; - No automatic shaking after sweeping/program or prior to emptying.
2	<ul style="list-style-type: none"> - Shaking continues as long as button is pressed; - Filter vacuum is switched on with sweeping/program; - No automatic shaking prior to emptying (raise).
3	<ul style="list-style-type: none"> - Filter vacuum is switched on with sweeping/program; - Automatic shaking prior to emptying (raise); - No manual shaking as long as button remains pressed; - No manual shaking after sweeping/program.
4	<ul style="list-style-type: none"> - Filter vacuum is switched on with sweeping/program; - Automatic shaking after sweeping/program; - No automatic shaking prior to emptying; - No manual shaking as long as button remains pressed.
5	<ul style="list-style-type: none"> - Shaking continues as long as button is pressed; - Filter vacuum is not switched on with sweeping/program; - No automatic shaking after sweeping/program or prior to emptying.



6	<ul style="list-style-type: none">- Automatic shaking prior to emptying (raise);- No automatic shaking after sweeping/program;- No manual shaking as long as button remains pressed;- Filter vacuum is not switched on with sweeping/program.
7	<ul style="list-style-type: none">- Automatic shaking after sweeping/program;- No manual shaking as long as button remains pressed;- No automatic shaking prior to emptying;- Filter vacuum is not switched on with sweeping/program.

4.2.2.4 Setting 3: Programmable program versions (PPV)

The settings described in this step must be adjusted according to customer demands. An adjustment defined at the factory must not necessarily be used.

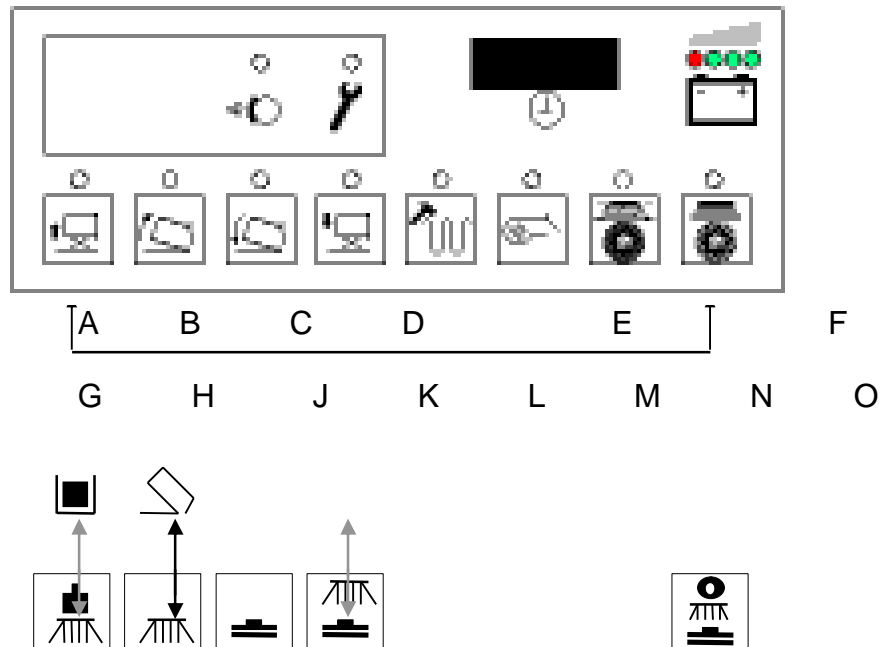

Accessing the programming function

Switch off the vehicle using the key switch.

Press and hold buttons "G" and "O" simultaneously and then switch the key switch on.

Keep both buttons pressed until the display of the software version is replaced by a dashes and then release both buttons.

The display contains the programmed settings for the following options:

Display of the last (cleared) error (for approx. 5 seconds) after switching on: yes / no

Switch to basic settings after switching on: yes / no

Seat switch delay: program. Time / none

Sweeping automatically off prior to shaking: yes / no

Filter vacuum on after shaking: delayed / immediately

Shake filter: in intervals / as long as button is pressed

Automatic shaking prior to emptying: yes / no

Automatic filter shaking when sweeping/program has ended: yes / no

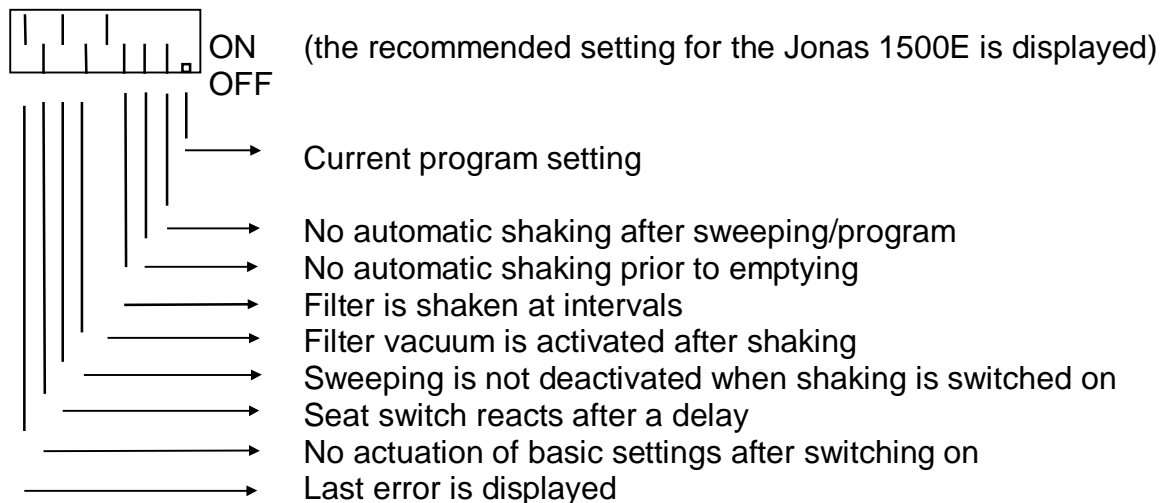

Display last error

Select the required setting using the buttons "G" and "K".

The bar of the setting to be changed flashes.

Use button "H" to move the bar up and down.

Up = ON = diagnostic code (of error cleared) appears in the display for approx. 5 seconds after switching the vehicle on.

Down = OFF = diagnostic code (of error cleared) is not displayed.

Save the setting by pressing and holding the green button ("O") until a point appears at the bottom right of the display.

Basic setting after switching on

Select the required setting using the buttons "G" and "K".

The bar of the setting to be changed flashes.

Use button "H" to move the bar up and down.

Up = ON = Basic setting is set on pressing the Program button ("O")

Down = OFF = Basic setting is not set, i.e. current status is not altered.

Save the setting by pressing and holding the green button ("O") until a point appears at the bottom right of the display.

Seat switch delay

Select the required setting using the buttons "G" and "K".

The bar of the setting to be changed flashes.

Use button "H" to move the bar up and down.

Up = ON = The seat switch circuit is activated after a programmed time

Down = OFF = The seat switch is activated immediately, without a delay.

Save the setting by pressing and holding the green button ("O") until a point appears at the bottom right of the display.

Sweeping automatically off prior to shaking

Select the required setting using the buttons "G" and "K".

The bar of the setting to be changed flashes.

Use button "H" to move the bar up and down.

Up = ON = Sweeping is interrupted as soon as shaking is selected (button "L")

Down = OFF = Sweeping continues after shaking has been selected (button "L").

Save the setting by pressing and holding the green button ("O") until a point appears at the bottom right of the display.

Filter vacuum on after shaking

Select the required setting using the buttons "G" and "K".

The bar of the setting to be changed flashes.

Use button "H" to move the bar up and down.

Up = ON = Filter vacuum is switched on following a delay after the shaking function

Down = OFF = Filter vacuum is switched on immediately after shaking.

Save the setting by pressing and holding the green button ("O") until a point appears at the bottom right of the display.

Shake filter

Select the required setting using the buttons "G" and "K".

The bar of the setting to be changed flashes.

Use button "H" to move the bar up and down.

Up = ON = Filter continues to be shaken as long as the button remains pressed

Down = OFF = Filter is shaken in 7 intervals (default setting) after switching on (button "L").

Save the setting by pressing and holding the green button ("O") until a point appears at the bottom right of the display.

Automatic shaking prior to emptying (raise)

Select the required setting using the buttons "G" and "K".

The bar of the setting to be changed flashes.

Use button "H" to move the bar up and down

Up = ON = Automatic shaking is performed before the dirt hopper is raised

Down = OFF = Dirt hopper can be emptied without prior automatic shaking.

Save the setting by pressing and holding the green button ("O") until a point appears at the bottom right of the display.

Automatic filter shaking after sweeping/program

Select the required setting using the buttons "G" and "K".

The bar of the setting to be changed flashes.

Use button "H" to move the bar up and down

Up = ON = If the sweeping function is ended by pressing the green button "O", the shaking function is automatically switched on

Down = OFF = Shaking is not activated automatically when sweeping is ended.

Save the setting by pressing and holding the green button ("O") until a point appears at the bottom right of the display.

4.2.2.5 Setting 4: Setting the shaking intervals

Note: Normally, it is not necessary to set the shaking interval or to modify it. The interval only needs to be adapted in the case of extreme working conditions. If set incorrectly, it can lead to malfunction of the filter system.

Accessing the programming function

Switch off the vehicle using the key switch.

Press and hold button "L" and turn the key switch on.

Keep the button pressed until the display in the operating hour counter changes (initially shows the software version), then release the button.

The switch-on time display for the motor per cycle (t_{ON}) appears automatically. Press button "L" again to display the switch-off time per cycle (t_{OFF}) and again to display the number of cycles (c). The corresponding values can be changed by pressing button "G" (ascending order) and button "K" (descending order). Save the new values by pressing button "O" (press and hold until the outer point in the display lights up).

Exit from the programming function at any time by switching off the key switch.

The values can be altered within the following ranges:

t_{ON} = 0.05 - - - 2.50 sec

t_{OFF} = 0.05 - - - 2.50 sec

c = 1 - - - 10

The default settings ($t_{ON} = 0.60$ sec, $t_{OFF} = 1.30$ sec, $c = 7$) can be reset by pressing the button "L" for over 3 second (in Setup mode).

4.2.2.6 Setting module 3 (Code A and Code B):

The DIP switches on module 3 must be set correctly because they influence the module coding and semiconductor fuse.

Module 3 Code A (-A2):

1: OFF
2: OFF
3: OFF
4: OFF

semic. Fuses:

F1	5A
F2	63A
F3	2A
F4	20A
F5	20A
F6	5A
F7	30A

Module 3 Code B (-A3):

1: ON
2: OFF
3: OFF
4: OFF

semic. Fuses:

F1	5A
F2	50A
F3	2A
F4	5A
F5	5A
F6	5A
F7	5A

4.2.3 Error messages

Diagnostic code in display	Error	Comment
2.2.5.1.	Thermostatic switch, Main rotary brush	Is the engine overloaded? (Continuous driving with increased rotary brush pressure?) Thermostatic switch defective? Or cable break, NOC switching? Test: Bridge Pin 1 and Pin 2 on connector –A2.X21. If diagnostic code still appears, Module 3 Code A (-A2) probably defective.
2.1.4.1.	Anti-blocking system, raise/lower shuttle valve HB/SB	Short-term overloading. Acknowledge via green button (basic setting).
2.2.6.1.	Anti-blocking system, Main rotary brush	Semiconductor fuse: Motor briefly overloaded. Rotary brush possibly blocked by foreign bodies, tape or such.
2.3.5.1.	Thermostatic switch, Motor, side brushes left and right	Motor too hot. Brush contact area possible too large or foreign body in brush?

2.3.6.1.	Anti-blocking system, Motor, side brush left	Motor briefly overloaded, e.g. run against curb or wall. Consequence: Acoustic signal and SB motor switched off briefly. Following 3 successive occurrences, SB motor is switched off and brush is raised
2.3.6.2.	Anti-blocking system, Motor, side brush right	Refer to 2.3.6.1. (Left-hand side brush.)
2.3.3.2.	Status, PWM module, left-hand side brush	Module –A8 check fuse
2.3.6.4.	Anti-blocking system valve, lower side brush	Is lowering sluggish?
2.2.4.2.	Anti-blocking system valve, main brush	Sluggish? Incorrect sweeping pattern setting?
2.3.6.5.	Status, PWM module, right-hand side brush	Module –A7 check fuse
2.4.5.1.	Thermostatic switch, suction turbine	Suction turbine motor too hot; filter defective? Air flow volume is too large? Belt tension is too strong?
2.4.6.1.	Anti-blocking system, suction turbine	Short-term overloading of the fan motor; cause possibly as with 2.4.5.1.
2.6.6.1.	Anti-blocking system valve, pivot dirt hopper	Sluggish? Cylinder OK?

3.1.6.2.	Safety fuse, Module 3 Code A (-A2)	Check all fuses on –A2
3.1.6.3.	Safety fuse, Module 3 Code B (-A3)	Check all fuses on –A3
3.1.6.7.	Safety fuse, control electronics	No voltage supply to the modules.
3.1.6.8.	Fuse, PWM module, left- hand side brush	Module –A8
3.1.6.9.	Fuse, PWM module, right-hand side brush	Module –A7
3.2.1.1.	Total discharge signal transducer (TSG) defective	Measure battery voltage on the control electronic –A1.X2 between Pin 1 and Pin 4 (36 V), also when the vehicle is switched off. If it is not OK, check the cable connection to the battery plug. Check the DIP switches for the TSG setting on –A1. If OK and 3.2.1.1.still occurs, replace –A1
3.3.5.1.	Thermostatic switch, hydraulic motor	Sluggish? Raise hopper deactivated. Acknowledge using Raise Hopper button

3.4.5.1.	Hydraulic motor hot	Does traction drive run smoothly? Is the parking brake set correctly? Frequent driving up gradients? Possible cable break, NOC switching?
3.6.6.4.	Time out seat contact	Check seat contact switch for function
4.3.2.1.	Module 3 Code A not detected (-A2)	DIP switch on –A2 set incorrectly? Check CAN bus connection.
4.3.2.2.	Module 3 Code B not detected (-A3)	DIP switch on –A3 set incorrectly? Check CAN bus connection.
4.3.3.1.	Module 3 Code A no reply (timeout) (-A2)	Check CAN bus connection.
4.3.3.2.	Module 3 Code B no reply (timeout) (-A3)	Check CAN bus connection.
4.6.1.1.	Internal SE error	Check all plug connections on –A1 regarding corrosion; check power supply (voltage converter).
4.6.2.1.	CAN bus error (no reply – timeout)	Check CAN bus cabling between control electronic –A1 and modules, check plug connections and contacts (resistance 120Ω)

4.6.3.1.	CAN bus error	Check CAN bus cabling between control electronic –A1 and modules, check plug connections and contacts (resistance 120Ω)
4.6.3.2.	CAN bus error (overrun)	Check CAN bus cabling between control electronic –A1 and modules, check plug connections and contacts (resistance 120Ω)
4.6.5.1.	Vehicle software not implemented	Check whether EPROM on control unit –A1 is fitted properly
4.6.5.2.	Options set are not possible	DIP switch set incorrectly for the options
4.6.5.3.	Module projection (too much of module in the vehicle)	Check DIP switch for the options on the control unit –A1 and DIP switch on modules –A2 and –A3

4.2.4 Modules

4.2.4.1 A1

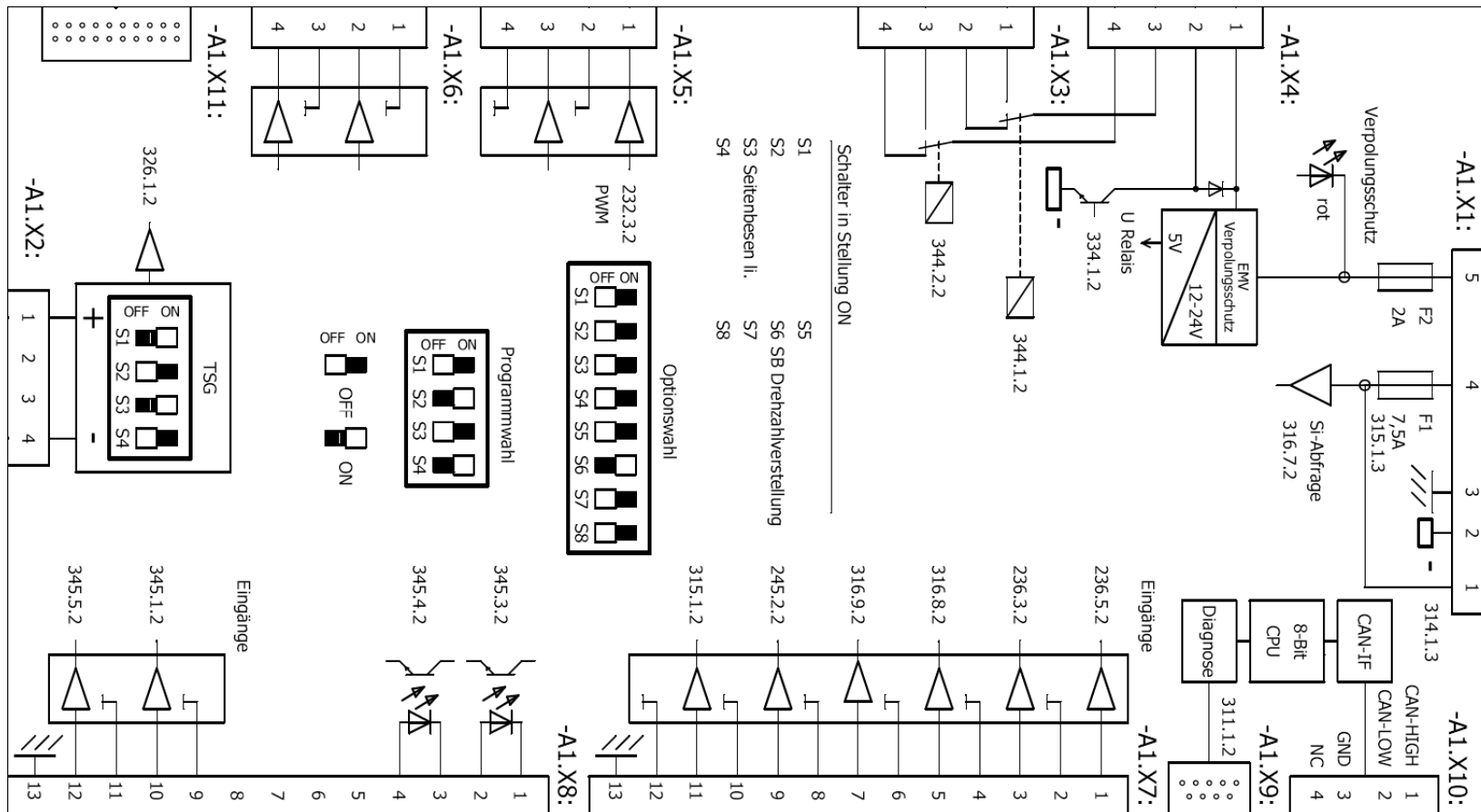

A1 is located underneath the left-hand operating panel

4.2.4.2 A2 + A3

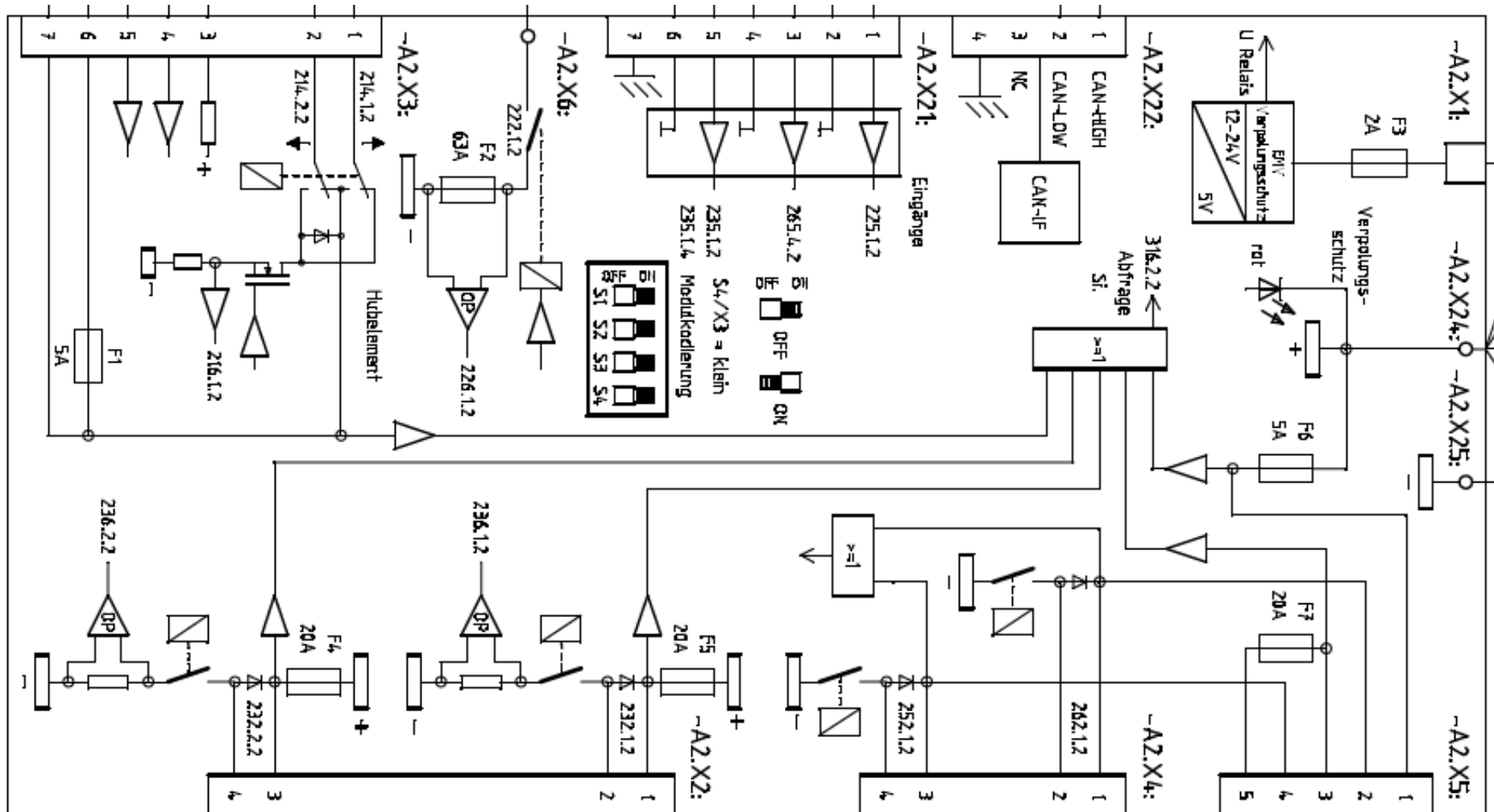

The two boards, A2 and A3, are located between the left frame and the suction fan. The boards A7 and A8 are under a cover at the left front cover.

4.2.5 Drive control

A ZAPI drive control is used in the J1500E. It is an H0 230 type. The control unit can be ordered under spare part no. 01153460. It is fully configured and no setup work is necessary. The controller is located at the left frame (before the fan).

Circuit diagram

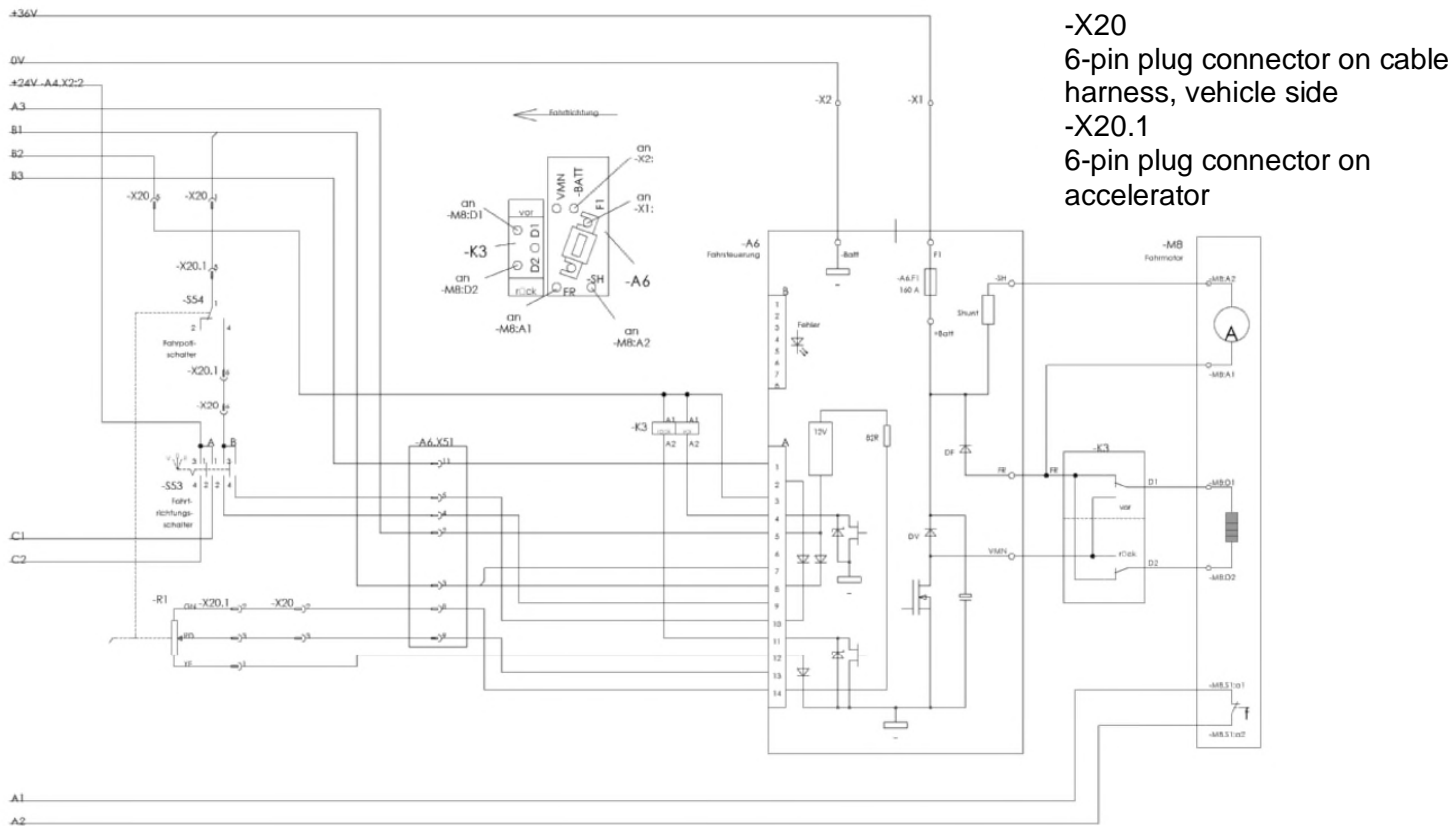

Some monitoring functions are realized via the drive control.

Four sections are monitored:

- 1) When switching on (key switch ON)
 - Watchdog
 - Current sensor
 - Power output MOS FET
 - Triggering of contactor
 - Driving direction signal
 - Potentiometer connections
 - EEPROM
- 2) Idling phase (ignition on/no function)
 - Watchdog
 - Current
 - Triggering of contactor
 - Power output MOS FET
 - Potentiometer connections
- 3) Driving
 - Watchdog
 - Current
 - Triggering of contactor
 - Potentiometer connections
 - Closing and opening of contactors
- 4) Continuously
 - Temperature of the power supply
 - Battery voltage

4.2.5.1 Error messages

Errors are indicated by means of an LED at connector B.

Blink code	Error message	Status	Description
1	WATCH DOG	A	Error in the electronic system
1	EEPROM KO	A	Error in the electronic system (EEPROM)
2	INCORRECT START	B	A driving direction is actuated during start up (or IR is connected wrongly)
3	VMN LOW	B	MOSFET is short-circuited
3	VMN HIGH	B	Diodes short-circuited or drive direction contactor jammed
4	VACC NOT OK	B	Potentiometer defective
5	I=0 EVER	A	No current flow detected while driving
5	HIGH CURRENT	A	Current flows during idling phase
6	PEDAL WIRE KO	B	Potentiometer wiring is defective
7	TEMPERATURE	C	Temperature > 76°C
8	DRIVER 1 KO	A	Driver NT1 short-circuited
8	DRIVER 1 SIC KO	A	Contacto coil on NT1 short-circuited
8	DRIVER 2 KO	A	Driver NT2 short-circuited
8	DRIVER 2 SIC KO	A	Contacto coil on NT2 short-circuited
8	DRIVER SHORTED	B	Driver short-circuited
8	CONTACTOR OPEN	B	Contacto does not close
9	POSITION HANDLE	B	Drawbar microswitch not actuated
9	INVERSION	B	Dead man's impact switch (IR) actuated or connected incorrectly
Cont. flashing	BATTERY	C	Battery discharged too much
Cont. on	FORW + BACK	B	Both driving directions selected simultaneously

Status:
 A: Switch system off; clear error; restart system
 B: Clear error; actuate driving direction again
 C: status indicator and initiate software-controlled measure as necessary

Help on fault location:

1) WATCHDOG

Test both in idling phase as well as while driving; internal self-test of hardware and software; in case of error, replace the control unit!

2) EEPROM PAR.KO

Error related to the memory area which contains the values of the setting parameters. The system switches off. If the error continues after having switched the key switch off and on again, replace the logic! When the alarm stops, pay attention that the parameter values stored are deleted. (—> Basic setting)

3) EEPROM CONF. KO

Error related to the memory area which contains the configuration data of the control unit. If the error continues after having switched the key switch off and on again, replace the logic! When the alarm stops, pay attention that the configuration stored is deleted. (—> Basic setting)

4) EEPROM DATAKO

The data in the memory area which controls the operating hour counter is no longer correct. If the alarm stops after having switched the key switch off and on again, pay attention that the hour counter is reset to zero.

5) EEPROM OFF LINE

Error in non-volatile memory which contains the values of the operating hour counter, the programmable parameters and alarm history. If the error continues after having switched the key switch off and on again, replace the control unit!

6) INCORRECT START

The sequence of start conditions is not correct. The system only starts up when the following sequence is maintained, according to how the SAFETY SWITCH is programmed:

- key switch - drawbar microswitch - direction switch (HANDLE)
- key switch - direction switch (FREE)
- key switch + seat switch - direction switch (SEAT)

Possible causes:

- a) The driving direction or drawbar microswitch has jammed.
- b) The operator has not observed the sequence.
- c) Incorrect wiring.

If no external fault is discovered, replace the control unit!

7) VMN LOW

Complete test in idling phase and while driving until VMN is synchronized up to 80%;

The voltage at the VMN connection is normally about 50% VBatt when the contactors are open. If this voltage is too low (< 30% VBatt), an alarm is issued. Possible causes:

- a) General contactor (if available) does not close or is not connected.
- b) Short circuit between the VMN connection and -Batt (metallic foreign body, or such). (Disconnect cable at VMN connection, switch on, error cleared).
- c) Power output MOSFET short-circuited or continuously triggered by the logic; (Disconnect cable at VMN connection, switch on, error remains, replace control unit).
- d) Bypass contactor (if available) is jammed or opens too slowly.

8) VMN HIGH

Test during idling phase;

The voltage at the VMN connection is normally about 50% VBatt when the contactors are open. If this voltage is too high (> 70% VBatt), an alarm is issued.

Possible causes:

- a) A drive direction contactor is continuously closed because of mechanical blocking or because it is constantly triggered (incorrect contactor coil wiring)
- b) Short circuit between the field winding and armature winding of the engine.
(Disconnect cable at VMN connection, switch on, error cleared, repair engine.)
- c) Engine cable connected incorrectly (check field winding and armature winding).
- d) Control unit power supply is defective (freewheeling or brake diodes short-circuited). (Disconnect cable at VMN connection, switch on, error remains, replace control unit).

9) VACC NOT OK

Test during idling phase;

An alarm is indicated when the potentiometer voltage is greater than 1 V related to the minimum voltage stored.

Possible causes:

- a) A wire on the potentiometer or inductive sensor has broken off.
- b) The potentiometer or inductive sensor is defective.

10) I=0 EVER

Test while driving;

If the current does not exceed a defined minimum value while driving, an error message appears and the system is switched off.

Possible causes:

- a) The engine resistance is too high because the engine is defective or the contact of the carbon brushes is not correct
- b) The current sensor is defective (replace control unit)

11) HIGH CURRENT

Test in idling phase, contactors open;

If the current measured is $>50\text{A}$, an alarm is issued and the system is switched off. The current sensor is defective (replace control unit).

12) PEDAL WIRE KO

If no voltage is measured at Pin NPOT (A12), to which the negative connection of the potentiometer is connected, an alarm is issued.

Possible causes:

- a) The wire at connection PPOT (A14) is broken.
- b) The wire at connection NPOT (A12) is broken.
- c) The potentiometer is defective (continuous resistance).
- d) The potentiometer has a resistance $>47\text{ kOhm}$.

13) TEMPERATURE

This message indicates that the temperature of the control unit has increased to over 76°C .

The maximum current is reduced in steps to zero at a temperature of 86°C .

Possible causes:

- a) If the alarm is triggered immediately after switching the system on with the control unit cold, the temperature monitoring function is not working correctly (replace control unit!)
- b) If the alarm is triggered after a relatively short operating time, the heat is not dissipated sufficiently (check installation and retaining screws)

14) NO FULL COND.

Test at full speed:

If the voltage at connection VMN $>1/3\text{ VBatt}$ at full speed, there is a fault in the diagnostic circuit and the system switches off.

If the fault continues, replace the control unit (logic part).

15) DRIVER1KO

If the voltage at connection NT1 (A11) does not correspond to the specified value, an alarm is issued and the system switches off.

Possible causes:

- a) The wire at connection NT1 (A11) is broken or the coils in the reverse drive direction contactor is defective.
- b) The internal MOSFET driver is short-circuited (replace control unit!)

16) DRIVER 1 SIC KO

If the current load at the contactor driver which triggers output NT1 (A11) is too high, an alarm is issued and the system switches off.

Possible causes:

- a) Short circuit of the wire at connection NT1 (A11) against +Batt
- b) Coils of the connected contactor have short-circuited or the power consumption > 5A.

17) DRIVER 2 KO

If the voltage at connection NT2 (A4) does not correspond to the specified value, an alarm is issued and the system switches off.

Possible causes:

- a) The wire at connection NT2 (A4) is broken or the coils in the forward drive direction contactor are defective.
- b) The internal MOSFET driver is short-circuited (replace control unit!).

18) DRIVER 2 SIC KO

If the current load at the contactor driver which triggers output NT2 (A4) is too high, an alarm is issued and the system switches off.

Possible causes:

- a) Short circuit of the wire at connection NT2 (A4) against +Batt.
- b) Coils of the connected contactor have short-circuited or the power consumption > 5A.

19) DRIVER SHORTED (only with H0 STANDARD TRACT.)

If the voltage at connection NT1 (A11) does not correspond to the specified value, an alarm is issued and the system switches off.

Possible causes:

- a) The wire at connection NT1 (A11) is broken or the coils in the forward or reverse drive direction contactor is defective.
- b) The internal MOSFET driver is short-circuited (replace control unit!)

20) CONTACTOR OPEN

Test on actuating a driving direction;

This tests whether the selected drive direction contactor closes. To do this, a measurement is made as to whether the VMN has the correct value. If this is not the case, an alarm is issued. Proceed as follows to clear cause:

When does the error occur?	1st Test	Result	2nd Test	Result	Error
Only with drive direction forwards	Drive direction forwards contactor closes for 0.3 sec and then	Yes	-->	-->	A1
		No	A voltage is applied to the coils of the drive direction forward contactor for 0.3 sec	Yes	B1
				No	C1
Only with drive direction reverse	Drive direction reverse contactor closes for 0.3 sec and then	Yes	-->	-->	A2
		No	A voltage is applied to the coils of the drive direction forward contactor for 0.3 sec	Yes	B2
				No	C2
In both drive directions	Drive direction contactor forwards or reverse (depending on direction selected) closes for 0.3 sec and then opens	Yes	-->	-->	A3
		No	A voltage is applied to the coils for 3 sec at the drive direction contactor forward or reverse (depending on direction selected)	Yes	B3
				No	C3

A1 The NO contact of the drive direction contactor forward (TA) or NC contact of the drive direction contactor reverse (TI) is soiled or blocked. Clean the contacts or replace if group of contactors, if necessary.

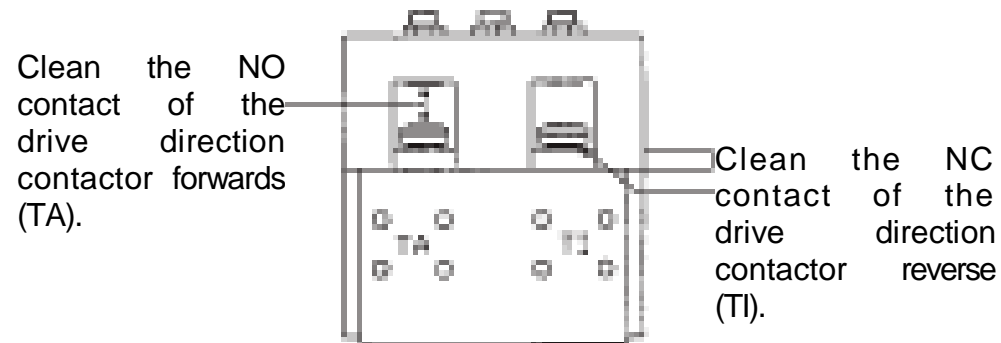

A2 The NC contact of the drive direction contactor forward (TA) or NO contact of the drive direction contactor reverse (TI) is soiled or blocked.

Clean the contacts or, if necessary, replace the contactor group.**A3**

There is no connection to the engine:

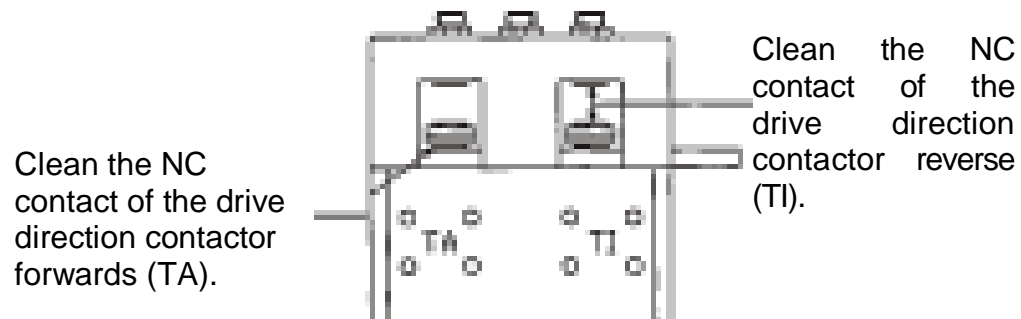

- Carbon brushes have no contact with the collector (Fig. 1)
- Carbon brush connection cable is broken (Fig. 2)
- Motor winding is defective or motor cable is broken
- Motor connected incorrectly

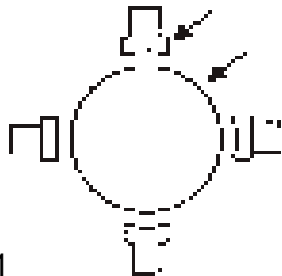

Fig. 1

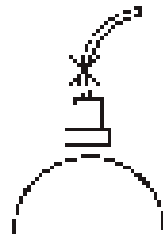

Fig. 2

B1 The drive direction contactor forwards is tripped correctly but does not close.

- the coil contactor is defective; measure the resistance with an ohmmeter
- the contact is mechanically blocked
- the nominal voltage of the contactor coil is higher than the battery voltage

B2 The drive direction contactor reverse is tripped correctly but does not close.

- the coil contactor is defective; measure the resistance with an ohmmeter
- the contact is mechanically blocked
- the nominal voltage of the contactor coil is higher than the battery voltage

B3 The drive direction contactor forward and reverse is tripped correctly but does not close.

- the contactor coils are defective; measure the resistance with an ohmmeter
- the contacts are mechanically blocked
- the nominal voltage of the contactor coils is higher than the battery voltage

C1 No voltage is applied to the coils of the drive direction contactor forward. Check the connector and cable from the contactor coil to the positive supply and to Pin A4 (NT2).

C2 No voltage is applied to the coils of the drive direction contactor reverse. PLUG
Check the connector and cable from the contactor coil to the positive supply and to Pin A11 (NT1).

C3 No voltage is applied to the coils of the drive direction contactor forwards and reverse. Check the connectors and cables from the contactor coils to the positive supply and to Pin A4 (NT2) and A11 (NT1).

If no fault is detected at Points C1, C2, C3, replace the logic.

21) POSITION HANDLE

If the drawbar microswitch has already been actuated when switching on, an error is signalled (only when SAFETY SWITCH is programmed to HANDLE). Possible causes:

- a) Drawbar microswitch has jammed
- b) Incorrect operation

22) INVERSION

If the dead man's switch is pressed during the switch-on routine, an alarm is issued.

Possible causes:

- a) Microswitch for emergency parking has jammed
- b) Incorrect operation
- c) Incorrect wiring or programming

23) FORW- BACK

An error is indicated when two drive directions are activated simultaneously. Possible causes:

- a) Wiring is defective.
- b) Driving direction microswitch has jammed. If neither of these causes applies, replace the logic!

24) BATTERY

The battery is empty, i.e., the voltage supplied has dropped below 60% of the nominal voltage. An alarm is issued. The system is switched off but can be restarted. The maximum current is then reduced to 50% of the programmed maximum current.

5.0 Maintenance

5.1 J1500 Diesel

Maintenance work	Once after 50 h	Every 250 h	Every 500 h	Every 1000 h
Change the engine oil	x	x	x	x
Change the engine oil filter	x	x	x	x
Check the engine speed (idling and operating speed)	x	x	x	x
Change the fuel filter			x	x
Check the main air filter element		x	x	x
Change the air filter safety cartridges				x
Change the coolant in the cooling system				x
Check the engine and hydraulic system for leaks	x	x	x	x
Change the hydraulic oil			x	x
Change the hydraulic oil filter	x		x	x
Check the electrical system	x	x	x	x
Change the brake shoes				x
Change the brake Bowden cables				x
Check the parking and service brakes	x	x	x	x
Check the traction drive (forward and reverse drive, neutral position)	x	x	x	x
Check the exhaust system		x	x	x
Check the tightening torque of the wheel bolts		x	x	x
Check the antistatic chain		x	x	x
Check the visual appearance of the vehicle	x	x	x	x
Test drive and function test	x	x	x	x

5.2 SWM D1500RH (Stufe V)

Maintenance work	Once after 50 h	Every 250 h	Every 500 h	Every 1000 h	alle 1000 h	alle 2000h
Check the visual appearance of the vehicle	X	X	X	X	X	X
Change the engine oil	X	X	X	X	X	X
Change the engine oil filter	X	X	X	X	X	X
Check the engine for leaks	X		X	X	X	X
Check the engine speed (idling and operating speed)	X		X	X	X	X
Check V-belt tension		X	X	X	X	X
Change V-belt				X	X	X
Clean the air filter main element		X	X	X	X	X
Check the air filter main element				X	X	X
Change the air filter safety cartridges					X	X
Check intake air hose			X	X	X	X
Clean the fuel filter		X	X	X	X	X
Change the fuel filter			X	X	X	X
Change the inline fuel filter				X	X	X
Rinse the water separator		X	X	X	X	X
Clean the water separator				X	X	X
Check battery	X	X	X	X	X	X
Change the coolant in the cooling system						X
Check coolant hoses			X	X	X	X
Check the valve clearance					X	X
Check exhaust system for leakage		X	X	X	X	X
Check service and parking brake	X		X	X	X	X
Change brake shoes					X	X
Change brake bowden cable					X	X
Check steering	X				X	X

Maintenance work	Once after 50 h	Every 250 h	Every 500 h	Every 1000 h	alle 1000 h	alle 2000h
Check torque of wheel bolts			X	X	X	X
Check neutral position of drive	X		X	X	X	X
Check hydraulic functions			X	X	X	X
Check the hydraulic system for leaks	X		X	X	X	X
Check hydraulic oil level	X	X	X	X	X	X
Change the hydraulic oil				X	X	X
Change the hydraulic oil filter	X			X	X	X
Check main broom for wear and damage		X	X	X	X	X
Check sweeping track mark		X	X	X	X	X
Check broom apron for adjustment, wear and damage		X	X	X	X	X
Check side broom for wear and damage		X	X	X	X	X
Check seal of hopper		X	X	X	X	X
Clean plate filter		X	X	X	X	X
Change plate filter				X	X	X
Check electric system	X		X	X	X	X
Function test		X				
Test drive and function test	X		X	X	X	X

Service-Handbuch

Service Booklet

5.3 J1500 gasoline



Maintenance work	Once after 50 h	Every 250 h	Every 500 h	Every 1000 h
Change the engine oil	x	x	x	x
Change the engine oil filter	x	x	x	x
Check the engine speed (idling and operating speed)	x	x	x	x
Change the fuel filter			x	x
Check the main air filter element		x	x	x
Change the air filter safety cartridges				x
Change the coolant in the cooling system				x
Check the engine and hydraulic system for leaks	x	x	x	x
Change the hydraulic oil			x	x
Change hydraulic oil filter	x		x	x
Check the electrical system	x	x	x	x
Change brake shoes				x
Change the brake Bowden cables				x
Check the parking and service brakes	x	x	x	x
Check the traction drive (forward and reverse drive, neutral position)	x	x	x	x
Check the exhaust system		x	x	x
Check the tightening torque of the wheel bolts		x	x	x
Check the antistatic chain		x	x	x
Check the visual appearance of the vehicle	x	x	x	x
Test drive and function test	x	x	x	x

Service-Handbuch

Service Booklet

5.4 J1500 LPG



Maintenance work	Once after 50 h	Every 250 h	Every 500 h	Every 1000 h
Change the engine oil	x	x	x	x
Change the engine oil filter	x	x	x	x
Check the engine speed (idling and operating speed)	x	x	x	x
Change the fuel filter			x	x
Check the main air filter element		x	x	x
Change the air filter safety cartridges				x
Change the coolant in the cooling system				x
Check the engine and hydraulic system for leaks	x	x	x	x
Change the hydraulic oil			x	x
Change the hydraulic oil filter	x		x	x
Check the electrical system	x	x	x	x
Change the brake shoes				x
Change the brake Bowden cables				x
Check the parking and service brakes	x	x	x	x
Check the traction drive (forward and reverse drive, neutral position)	x	x	x	x
Check the exhaust system		x	x	x
Check the tightening torque of the wheel bolts		x	x	x
Check the antistatic chain		x	x	x
Check the CO value (every 6 months)			x	x
Leak test of the LPG system (annually)				x
Check the visual appearance of the vehicle	x	x	x	x
Test drive and function test	x	x	x	x

5.5 SWM P1500 RH (Stage V)

Maintenance work	Once after 50 h	Every 125 h	Every 250 h	Every 500 h	Every 1000h	Every 2000h
Check the visual appearance of the vehicle	X	X	X	X	X	X
Change the engine oil	X		X	X	X	X
Change the engine oil filter	X		X	X	X	X
Check the engine for leaks	X		X	X	X	X
Check the engine speed (idling and operating speed)	X		X	X	X	X
Check V-belt tension		X	X	X	X	X
Change V-belt				X	X	X
Clean the air filter main element		X	X	X	X	X
Check the air filter main element			X	X	X	X
Clean the fuel filter		X	X	X	X	X
Change the fuel filter				X	X	X
Check battery	X	X	X	X	X	X
Clean spark plugs		X	X	X	X	X
Change spark plugs					X	X
Change the coolant in the cooling system						X
Check coolant hoses			X	X	X	X
Check the valve clearance					X	X
Check exhaust system for leakage		X	X	X	X	X
Check service and parking brake	X		X	X	X	X
Change brake shoes					X	X
Change brake bowden cable					X	X
Check steering	X				X	X
Check torque of wheel bolts			X	X	X	X
Check neutral position of drive	X		X	X	X	X

Maintenance work	Once after 50 h	Every 125 h	Every 250 h	Every 500 h	Every 1000h	Every 2000h
Check hydraulic functions			X	X	X	X
Check the hydraulic system for leaks	X		X	X	X	X
Check hydraulic oil level	X	X	X	X	X	X
Change the hydraulic oil	X			X	X	X
Change the hydraulic oil filter				X	X	X
Check main broom for wear and damage		X	X	X	X	X
Check sweeping track mark		X	X	X	X	X
Check broom apron for adjustment, wear and damage		X	X	X	X	X
Check side broom for wear and damage		X	X	X	X	X
Check seal of hopper		X	X	X	X	X
Clean plate filter		X	X	X	X	X
Change plate filter				X	X	X
Check electric system	X		X	X	X	X
Function test		X				
Test drive and function test	X		X	X	X	X

5.6 SWM P1500 RH_LPG (Stage V)

Maintenance work	Once after 50 h	Every 125 h	Every 250 h	Every 500 h	Every 6 Mon.	Every 1000h	Yearly	Every 2000h
Check the visual appearance of the vehicle	X	X	X	X		X		X
Change the engine oil	X		X	X		X		X
Change the engine oil filter	X		X	X		X		X
Check the engine for leaks	X		X	X		X		X
Check the engine speed (idling and operating speed)	X		X	X		X		X
Check V-belt tension		X	X	X		X		X
Change V-belt				X		X		X
Clean the air filter main element		X	X	X		X		X
Check the air filter main element			X	X		X		X
Visual check of LP system	X							
Check battery	X	X	X	X		X		X
Clean spark plugs		X	X	X		X		X
Change spark plugs						X		X
Change the coolant in the cooling system								X
Check coolant hoses			X	X		X		X
Check coolant hoses of vaporizer			X	X		X		X
Check CO value of LP system					X		X	
Check LP hoses						X		X
Check LP system for leakage							X	
Change vaporizer							X	
Check the valve clearance						X		X
Check exhaust system for leakage		X	X	X		X		X
Check service and parking brake	X		X	X		X		X
Change brake shoes						X		X

Service-Handbuch

Service Booklet

Page 129 of 124



Maintenance work	Once after 50 h	Every 125 h	Every 250 h	Every 500 h	Every 6 Mon.	Every 1000h	Yearly	Every 2000h
Change brake bowden cable						X		X
Check steering	X					X		X
Check torque of wheel bolts			X	X		X		X
Check neutral position of drive	X		X	X		X		X
Check hydraulic functions			X	X		X		X
Check the hydraulic system for leaks	X		X	X		X		X
Check hydraulic oil level	X	X	X	X		X		X
Change the hydraulic oil				X		X		X
Change the hydraulic oil filter	X			X		X		X
Check main broom for wear and damage		X	X	X		X		X
Check sweeping track mark		X	X	X		X		X
Check broom apron for adjustment, wear and damage		X	X	X		X		X
Check side broom for wear and damage		X	X	X		X		X
Check seal of hopper		X	X	X		X		X
Clean plate filter		X	X	X		X		X
Change plate filter				X		X		X
Check electric system	X		X	X		X		X
Function test		X						
Test drive and function test	X		X	X		X		X

5.7 J1500 electric system

Maintenance work	Once after 50 h	Every 125 h	Every 250 h	Every 500 h	Every 1000h
Check the battery acid density		X	X	X	X
Check the fan belt in terms of tension and properties		X	X	X	X
Change the brake shoes					X
Change the brake Bowden cables					X
Check the parking and service brakes	X	X	X	X	X
Check the hydraulic system for leaks	X	X	X	X	X
Change the hydraulic oil				X	X
Change hydraulic oil filter	X			X	X
Clean the electric motors				X	X
Check the carbon brushes of the electric motors for wear				X	X
Check the electrical system	X	X	X	X	X
Check the visual appearance of the vehicle	X	X	X	X	X
Test drive and function test	X	X	X	X	X